

Features

- Moderate Speed, CMOS Technology (25 nS)
- Complementary Outputs
- High Drive Current Capability (± 50 mA)
- Low Current Consumption
- Plastic SOIC Body for SMT Applications
- Tape and Reel Packaging Available
- Lead-Free SOIC-8 Package
- 100% Matte Tin Plating over Copper
- Halogen-Free “Green” Mold Compound
- 260°C Reflow Compatible
- RoHS* Compliant Version of DR65-0003

Description

M/A-COM's MADR-007097-000100 is a SPDT driver used to interface between TTL logic signals and PIN diode based microwave switches. High-speed analog CMOS technology is used to achieve low power consumption at moderate speeds. Low output resistances allow it to develop high output current spikes to ensure fast switching speeds. The complementary output stages are structured so it can be used as an inverting or non-inverting driver for SPST switches, or as a single input, complementary driver for SPDT switches. The monolithic die is packaged in a SO-8, plastic surface mount package and is available in tape and reel packaging for high volume applications. The MADR-007097-000100 driver is ideally suited for driving M/A-COM's line of HMIC switches.

Functional Block Diagram

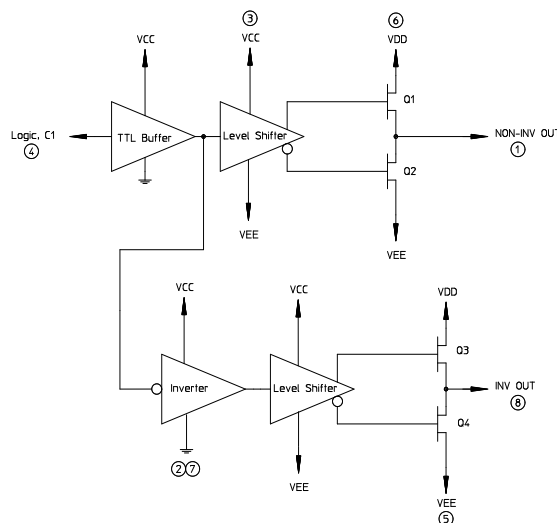

Ordering Information

Part Number	Package
MADR-007097-000100	Bulk Packaging
MADR-007097-0001TR	1000 piece reel

Note: Reference Application Note M513 for reel size information.

Pin Configuration

Pin No.	Function	Pin No.	Function
1	NON-INV OUT	5	VEE
2	GND	6	VDD
3	VCC	7	GND
4	C1 (TTL Logic)	8	INV OUT

* Restrictions on Hazardous Substances, European Union Directive 2002/95/EC.

Electrical Specifications: $T_A = +25^\circ\text{C}$, $+V_{CC} = +V_{DD} = +5.0\text{V} \pm 5\%$, $V_{EE} = -5.0\text{V} \pm 5\%$, $Z_0 = 50\Omega$

Parameter	Test Conditions	Units	Min	Typ	Max
Switching Speed ¹ Delay Rt/Ft	Spike current into 10 ohm load 50 % TTL to 90% 10%-90%; 90%-10%	ns	—	25	35
		ns	—	2	5
PRF	50% duty cycle	MHz	DC	—	5
Output Voltage Drop, No Load	With reference to supply voltage	V	—	—	0.25
DC Output Current Peak Spike Output Current	Load Dependant Spiking Capacitor in Circuit	mA	—	± 30	± 50
		mA	—	± 150	± 200
Output Stage on Resistance	Positive Output FET, Qp Negative Output FET, Qn	Ω	—	15	20
		Ω	—	10	15
Quiescent Supply Currents	+5V -5V	mA	—	—	1.5
		mA	—	—	.2
TTL Levels	Logic "0" @ 20 μA sink current Logic "1" @ 20 μA source current	V	0	—	.8
		V	2.0	—	5.0
Package Dissipation	—	mW	—	—	200

1. Decoupling capacitors (.01 μF) are required on power supply lines.

Absolute Maximum Ratings ^{2,3}

Parameter	Absolute Maximum
VCC	$-0.5\text{V} \leq V_{CC} \leq +7.0\text{V}$
VDD	$-0.5\text{V} \leq V_{DD} \leq V_{CC}$
VEE	$-7.0\text{V} \leq V_{EE} \leq +0.5\text{V}$
C1 (TTL Input Voltage)	-0.5V to $V_{CC} + 0.5\text{V}$
Operating Temperature	-40°C to $+85^\circ\text{C}$
Storage Temperature	-65°C to $+125^\circ\text{C}$

- Exceeding any one or combination of these limits may cause permanent damage to this device.
- M/A-COM does not recommend sustained operation near these survivability limits.

Handling Procedures

Please observe the following precautions to avoid damage:

Static Sensitivity

Silicon Integrated Circuits are sensitive to electrostatic discharge (ESD) and can be damaged by static electricity. Proper ESD control techniques should be used when handling these devices.

SPDT Microwave Switch with Driver

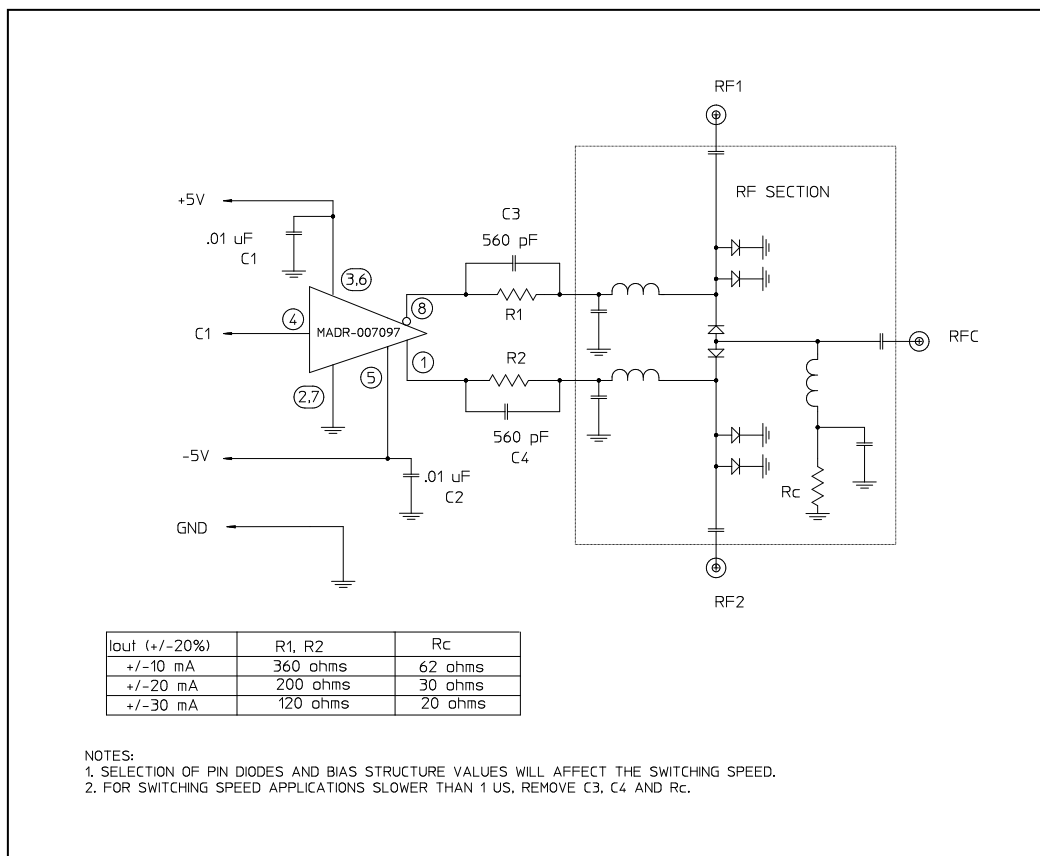

Lead-Free, SOIC-8[†]

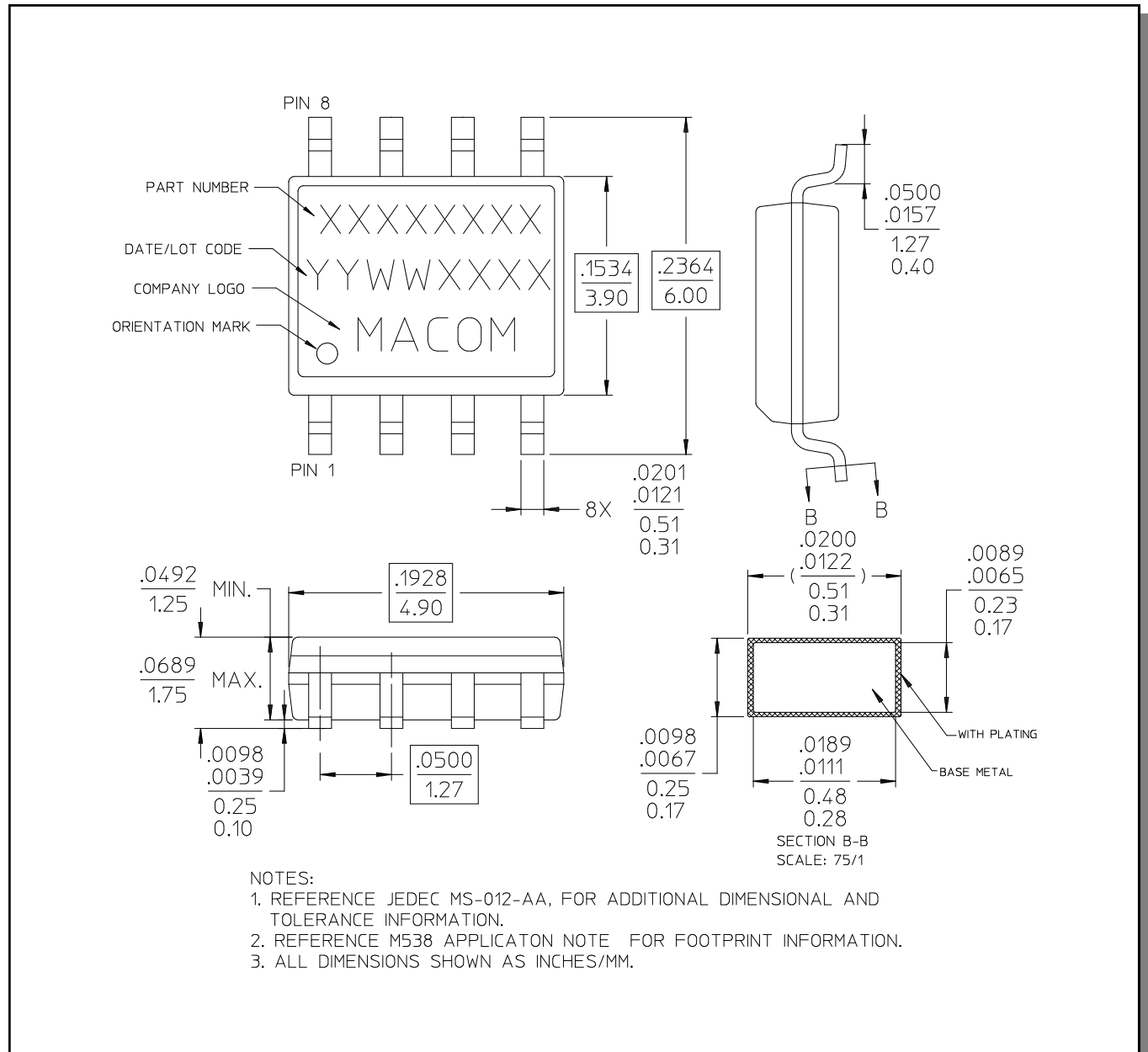

[†] Reference Application Note M538 for lead-free solder reflow recommendations.

M/A-COM Technology Solutions Inc. All rights reserved.

Information in this document is provided in connection with M/A-COM Technology Solutions Inc ("MACOM") products. These materials are provided by MACOM as a service to its customers and may be used for informational purposes only. Except as provided in MACOM's Terms and Conditions of Sale for such products or in any separate agreement related to this document, MACOM assumes no liability whatsoever. MACOM assumes no responsibility for errors or omissions in these materials. MACOM may make changes to specifications and product descriptions at any time, without notice. MACOM makes no commitment to update the information and shall have no responsibility whatsoever for conflicts or incompatibilities arising from future changes to its specifications and product descriptions. No license, express or implied, by estoppel or otherwise, to any intellectual property rights is granted by this document.

THESE MATERIALS ARE PROVIDED "AS IS" WITHOUT WARRANTY OF ANY KIND, EITHER EXPRESS OR IMPLIED, RELATING TO SALE AND/OR USE OF MACOM PRODUCTS INCLUDING LIABILITY OR WARRANTIES RELATING TO FITNESS FOR A PARTICULAR PURPOSE, CONSEQUENTIAL OR INCIDENTAL DAMAGES, MERCHANTABILITY, OR INFRINGEMENT OF ANY PATENT, COPYRIGHT OR OTHER INTELLECTUAL PROPERTY RIGHT. MACOM FURTHER DOES NOT WARRANT THE ACCURACY OR COMPLETENESS OF THE INFORMATION, TEXT, GRAPHICS OR OTHER ITEMS CONTAINED WITHIN THESE MATERIALS. MACOM SHALL NOT BE LIABLE FOR ANY SPECIAL, INDIRECT, INCIDENTAL, OR CONSEQUENTIAL DAMAGES, INCLUDING WITHOUT LIMITATION, LOST REVENUES OR LOST PROFITS, WHICH MAY RESULT FROM THE USE OF THESE MATERIALS.

MACOM products are not intended for use in medical, lifesaving or life sustaining applications. MACOM customers using or selling MACOM products for use in such applications do so at their own risk and agree to fully indemnify MACOM for any damages resulting from such improper use or sale.