

0.25 W Ka-Band Amplifier 27 - 31.5 GHz



MAAP-011340

Rev. V1

Features

- 25 dB Gain
- 33 dBm Output IP3
- 24 dBm P1dB
- 25 dBm P3dB
- 5.5 V Drain Supply
- 4 mm, 24 lead AQFN Package
- RoHS* Compliant

Applications

- Ka-Band Communication

Description

The MAAP-011340 is a 1/4 W Ka-band amplifier. The amplifier has a 24 dBm typical P1dB and a 25 dBm typical P3dB with 25 dB of gain. The typical IP3 is 33 dBm. The drain bias supply is 5.5 V. The gate voltage is adjusted to set the drain current to 275 mA.

The MAAP-011340 is designed for Ka-band satellite communication applications. The 4 mm, 24 lead AQFN package is lead free and RoHS compliant.

Block Diagram

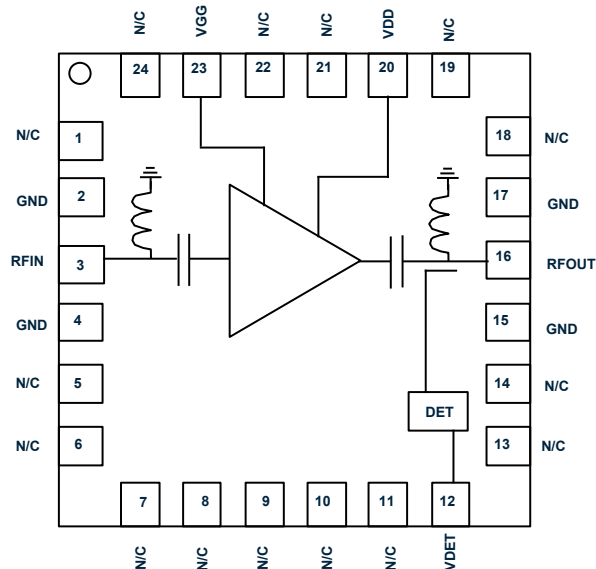

Pin Configuration^{2,3}

Pin #	Pin Name	Description
1,5-11, 13, 14, 18, 19, 21, 22, 24	N/C	No Connect
2,4,15,17	GND	Ground
3	RFIN	RF Input
12	VDET	Detector Voltage
16	RFOUT	RF Output
20	VDD	Drain Voltage
23	VGG	Gate Voltage

Ordering Information¹

Part Number	Package
MAAP-011340-TR1000	1000 Piece Reel
MAAP-011340-TR3000	3000 Piece Reel
MAAP-011340-SMB	Sample Board

1. Reference Application Note M513 for reel size information.

2. It is recommended that all NC (No Connect) pins be grounded.
3. The exposed pad centered on the package bottom must be connected to RF, DC, and thermal ground.

* Restrictions on Hazardous Substances, compliant to current RoHS EU directive.

0.25 W Ka-Band Amplifier

27 - 31.5 GHz



MAAP-011340

Rev. V1

Electrical Specifications:

Freq. = 27.0 - 31.5 GHz, $V_{DD} = +5.5$ V, $I_{DQ} = 275$ mA, $T_A = 25^\circ\text{C}$, $Z_0 = 50 \Omega$

Parameter	Test Conditions	Units	Min.	Typ.	Max.
Gain	—	dB	22	25	—
Gain Flatness	—	dB	—	± 0.7	—
Input Return Loss	—	dB	—	10	—
Output Return Loss	—	dB	—	10	—
P1dB	—	dBm	—	24	—
P3dB	—	dBm	—	25	—
P_{OUT}	27 GHz, $P_{IN} = 4.0$ dBm 31.5 GHz, $P_{IN} = 4.0$ dBm	dBm	24.5 23.5	25.5 24.5	—
Output IP3	$P_{OUT} = 16$ dBm per tone with 10 MHz spacing	dBm	—	33	—
Noise Figure	—	dB	—	6.1	—
V_{DET}	0 dBm Output Power 24 dBm Output Power	V	— 1.4	0.6 1.8	— 2.1
V_{GG}	Small Signal	V	—	-0.68	—
I_{GG}	Small Signal P3dB	mA	—	-0.7 -0.8	—
I_{DD}	P1dB P3dB	mA	—	300 320	—

Bias Sequence

All gate voltages must be applied prior to applying drain voltages.

1. Apply V_{GG} (about -0.75 V) to pin 23.
2. Apply V_{DD} (+5.5 V) to pin 20.
3. Adjust V_{GG} to set I_{DQ} to 275 mA.

Shut down by removing V_{DD} first.

Maximum Operating Conditions

Parameter	Maximum
TX Input Power	+5 dBm
V_{DD}	+6 V
V_{GG}	-3 to 0 V
Junction Temperature ^{4,5}	+160°C
Operating Temperature	-40°C to +85°C

4. Operating at nominal conditions with $T_J \leq +160^\circ\text{C}$ will ensure $MTTF > 1 \times 10^6$ hours.
5. TX Junction Temp. (T_J) = $T_C + \Theta_{jc} * ((V * I) - (P_{OUT} - P_{IN}))$.
Typical TX thermal resistance (Θ_{jc}) = 42°C/W.
a) For $T_C = +85^\circ\text{C}$,
 $T_J = 148.5^\circ\text{C}$ @ 5.5 V, 275 mA

Static Sensitivity

These electronic devices are sensitive to electrostatic discharge (ESD) and can be damaged by static electricity. Proper ESD control techniques should be used when handling these HBM Class 1C and CDM Class C2A devices.

Absolute Maximum Ratings^{6,7}

Parameter	Absolute Maximum
TX Input Power	+8 dBm
V_{DD}	+6.5 V
V_{GG}	-5 to 0 V
Junction Temperature ⁸	+175°C
Storage Temperature	-65°C to +125°C

6. Exceeding any one or combination of these limits may cause permanent damage to this device.
7. MACOM does not recommend sustained operation near these survivability limits.
8. Junction temperature directly effects device MTTF. Junction temperature should be kept as low as possible to maximize lifetime.

2

MACOM Technology Solutions Inc. (MACOM) and its affiliates reserve the right to make changes to the product(s) or information contained herein without notice. Visit www.macom.com for additional data sheets and product information.

For further information and support please visit:
<https://www.macom.com/support>

DC-0023977

Application Schematic

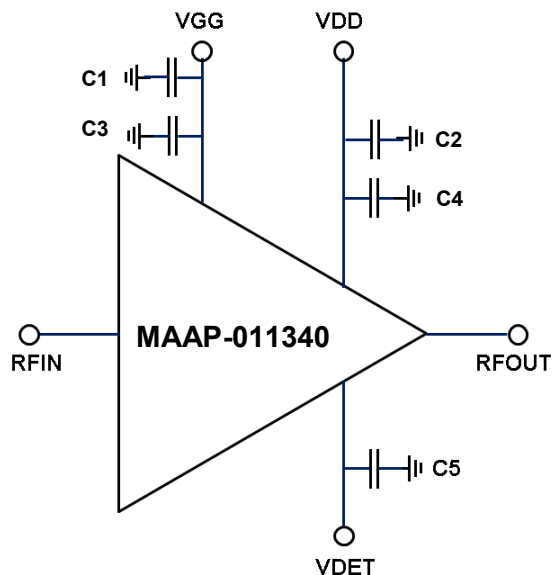

Parts List

Part #	Value	Case Style
C1, C2	10 μ F	1210
C3, C4	1000 pF	0402
C5	1 μ F	0402
J1, J2	100-mil pitch double row DC header	
J3 - J6	Southwest 2.4 mm, 5 mil pin diameter	

Recommended PCB Information

RF input and output are 50 Ω transmission lines on single layer 7.3 mil Rogers RO4350B LoPro with 1.5 oz. Cu. For best thermal management, use as many copper filled vias under the device as physically possible. The filled vias should be plated over. 8 mil diameter vias in a 5 x 5 array are used on this sample board.

PCB Layout Stack-Up

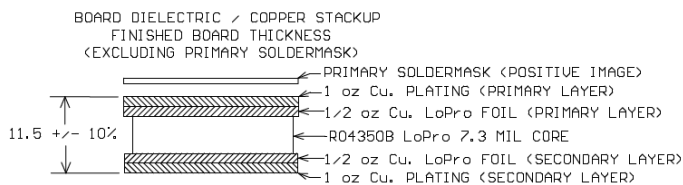

Finished board thickness is in mils

Sample Board Layout

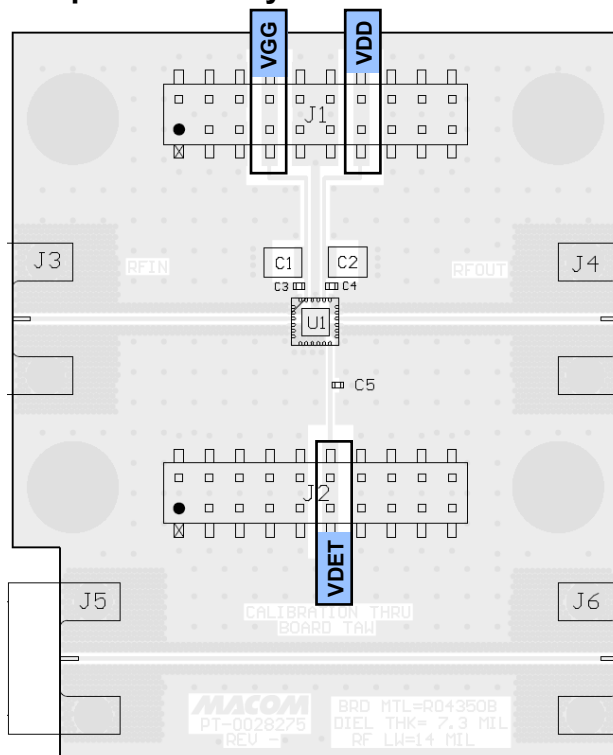

Sample Board Thru Line Loss

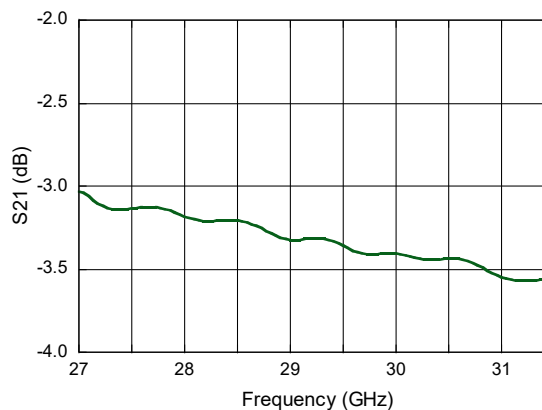

0.25 W Ka-Band Amplifier 27 - 31.5 GHz



MAAP-011340

Rev. V1

Typical Performance Curves:

Small Signal Gain vs. Frequency over Temperature

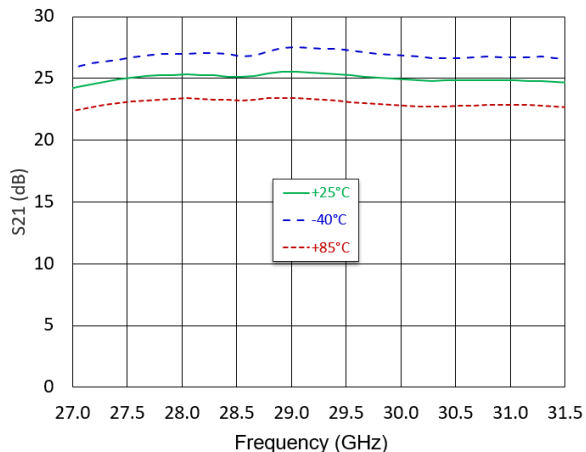

Small Signal Gain vs. Frequency over Bias Voltage

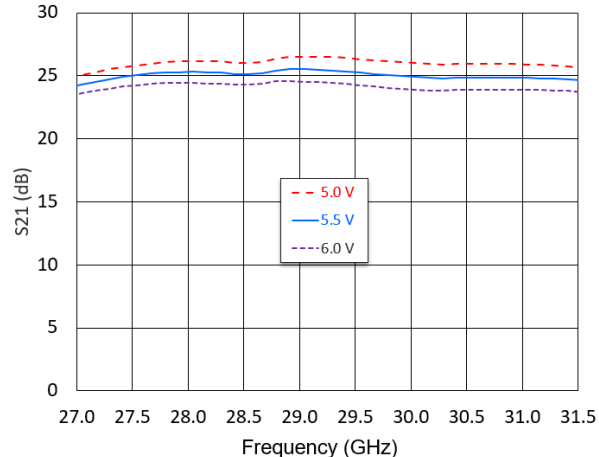

Input Return Loss vs. Frequency over Temperature

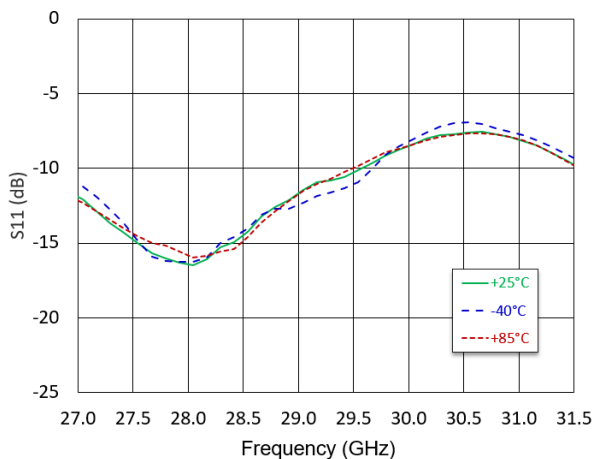

Input Return Loss vs. Frequency over Bias Voltage

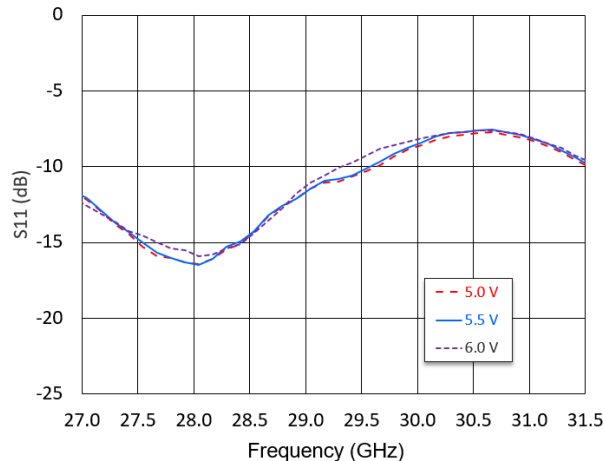

Output Return Loss vs. Frequency over Temperature

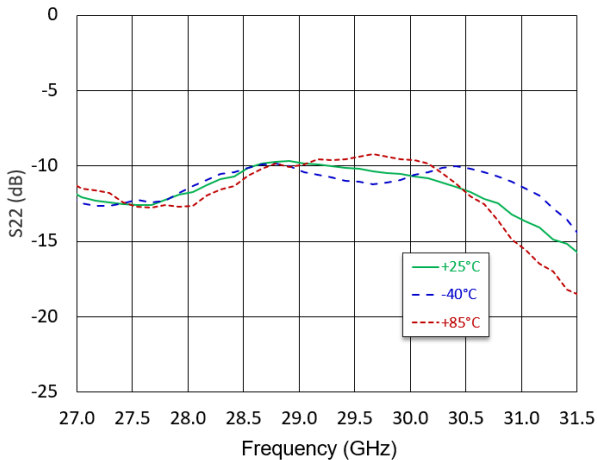

Output Return Loss vs. Frequency over Bias Voltage

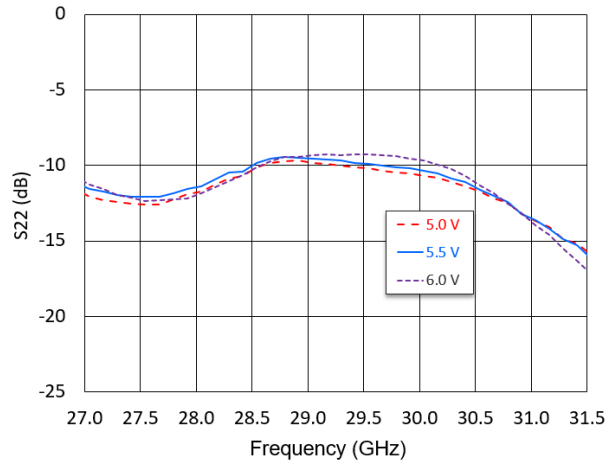

0.25 W Ka-Band Amplifier 27 - 31.5 GHz



MAAP-011340

Rev. V1

Typical Performance Curves:

P1dB vs. Frequency over Temperature

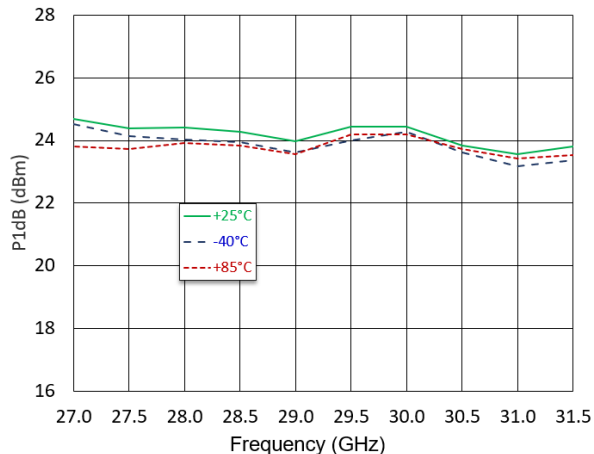

P1dB vs. Frequency over Bias Voltage

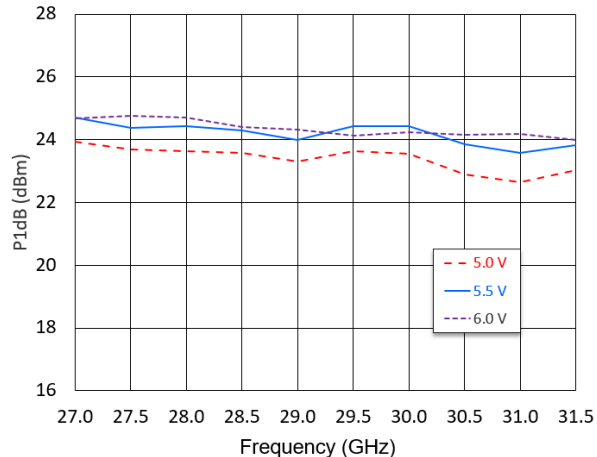

P3dB vs. Frequency over Temperature

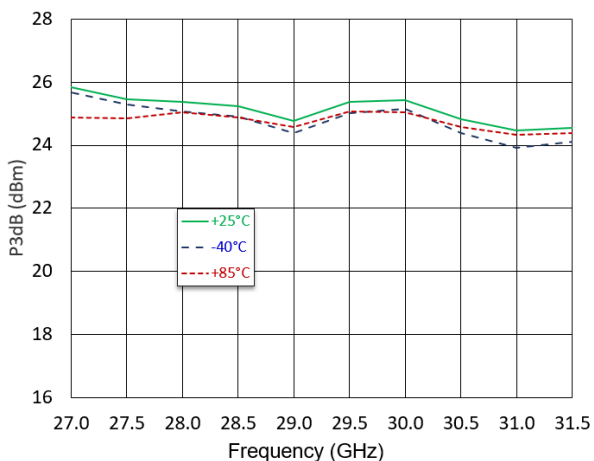

P3dB vs. Frequency over Bias Voltage

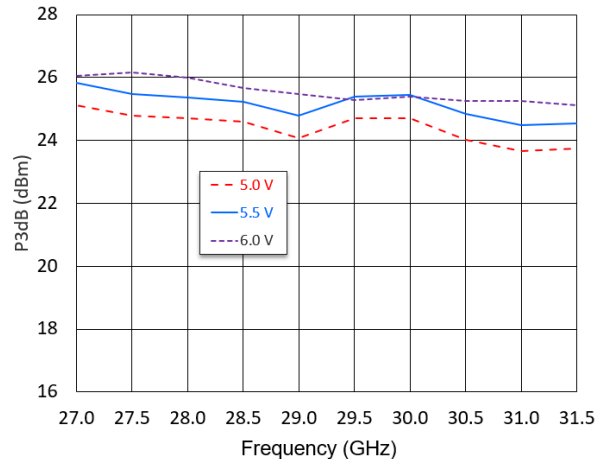

Noise Figure vs. Frequency over Temperature

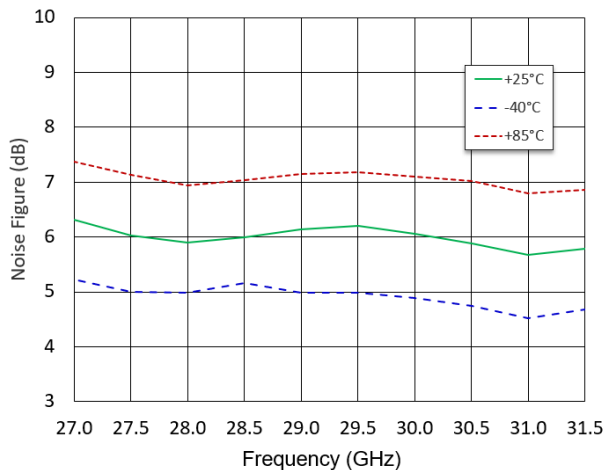

Noise Figure vs. Frequency over Bias Voltage

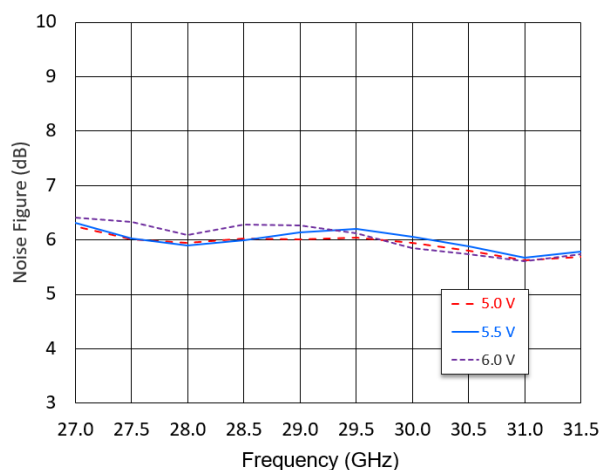

0.25 W Ka-Band Amplifier 27 - 31.5 GHz



MAAP-011340

Rev. V1

Typical Performance Curves:

OIP3 over Temperature ($P_{OUT} = 16 \text{ dBm} / \text{Tone}$)

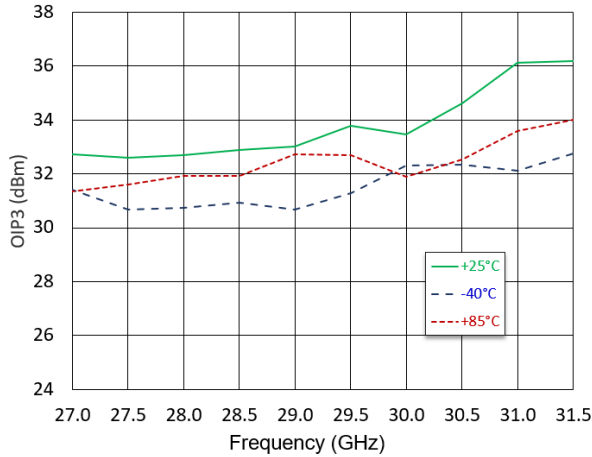

OIP3 over Bias Voltage ($P_{OUT} = 16 \text{ dBm} / \text{Tone}$)

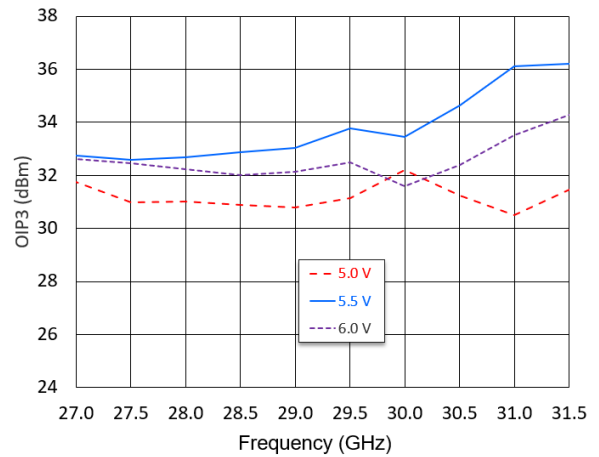

OIP3 vs. Output Power @ 25C

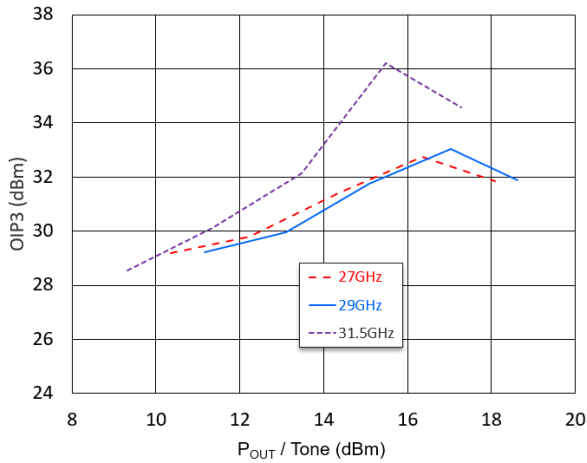

Detector Voltage vs. Output Power @ 25C

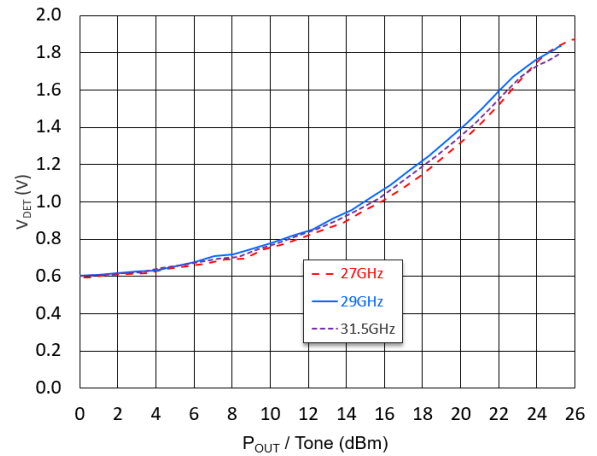

0.25 W Ka-Band Amplifier 27 - 31.5 GHz



MAAP-011340

Rev. V1

Lead-Free 4 mm 24-Lead AQFN Package[†]

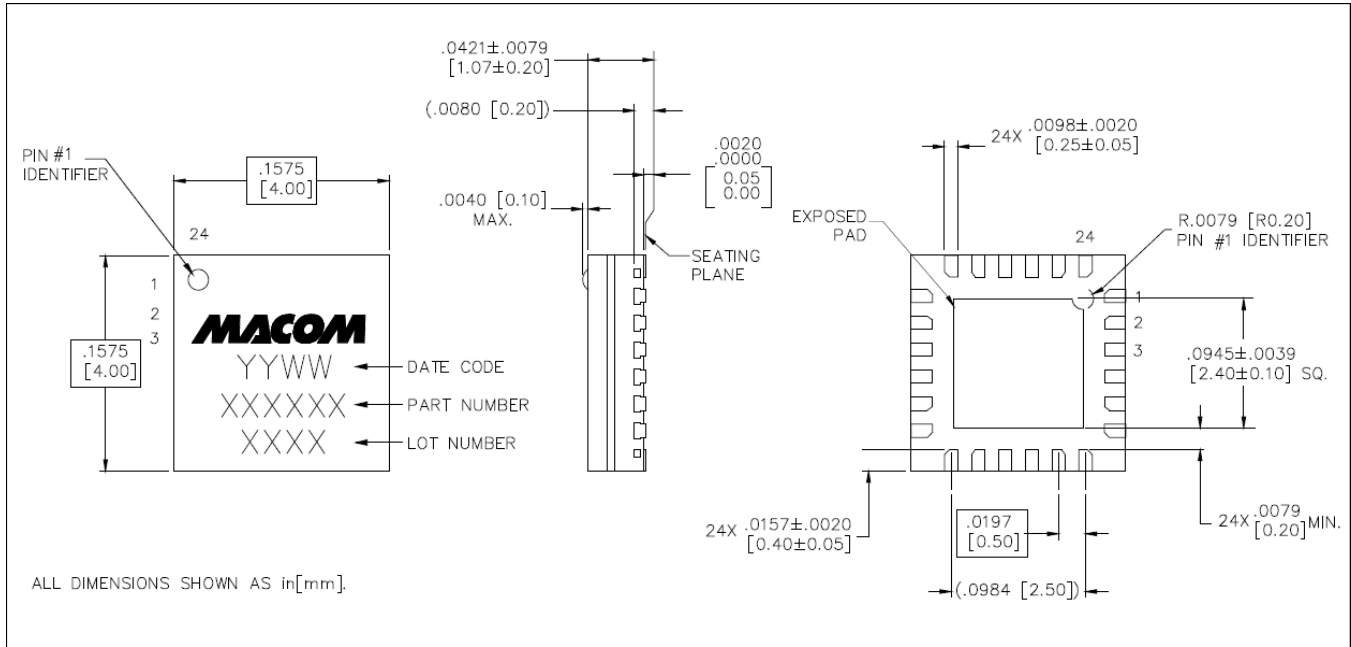

[†] Reference Application Note S2083 for lead-free solder reflow recommendations.
Meets JEDEC moisture sensitivity level 3 requirements.
Plating is NiPdAu

0.25 W Ka-Band Amplifier 27 - 31.5 GHz



MAAP-011340

Rev. V1

MACOM Technology Solutions Inc. ("MACOM"). All rights reserved.

These materials are provided in connection with MACOM's products as a service to its customers and may be used for informational purposes only. Except as provided in its Terms and Conditions of Sale or any separate agreement, MACOM assumes no liability or responsibility whatsoever, including for (i) errors or omissions in these materials; (ii) failure to update these materials; or (iii) conflicts or incompatibilities arising from future changes to specifications and product descriptions, which MACOM may make at any time, without notice. These materials grant no license, express or implied, to any intellectual property rights.

THESE MATERIALS ARE PROVIDED "AS IS" WITH NO WARRANTY OR LIABILITY, EXPRESS OR IMPLIED, RELATING TO SALE AND/OR USE OF MACOM PRODUCTS INCLUDING FITNESS FOR A PARTICULAR PURPOSE, MERCHANTABILITY, INFRINGEMENT OF INTELLECTUAL PROPERTY RIGHT, ACCURACY OR COMPLETENESS, OR SPECIAL, INDIRECT, INCIDENTAL, OR CONSEQUENTIAL DAMAGES WHICH MAY RESULT FROM USE OF THESE MATERIALS.

MACOM products are not intended for use in medical, lifesaving or life sustaining applications. MACOM customers using or selling MACOM products for use in such applications do so at their own risk and agree to fully indemnify MACOM for any damages resulting from such improper use or sale.