

Broadband Low Noise Gain Block, Die, 16 dB 0.03 - 8 GHz



MAAM-011305-DIE

Rev. V1

Features

- 16 dB Flat Broadband Gain to 8 GHz
- Low Noise Figure:
 - 1.6 dB Noise Figure to 1.5 GHz
 - 2.5 dB Noise Figure @ 6 GHz
 - 3.6 dB Noise Figure @ 8 GHz
- High Linearity OIP3:
 - 38 dBm @ 1.5 GHz
 - 32 dBm @ 6 GHz
 - 27 dBm @ 8 GHz
- Internal Matching to 50 Ω
- Single Voltage Bias: 3 - 5 V
- Integrated Active Bias Circuit
- RoHS* Compliant

Applications

- ISM/MM

Description

The MAAM-011305-DIE is a broadband high dynamic range, single stage MMIC LNA. This bare die is 0.795 x 0.66 mm. The amplifier is internally matched to provide flat gain and good return losses to 8 GHz without any external matching components. Only DC blocking capacitors and an RF choke with bypass capacitance is required.

This low noise amplifier has an integrated active bias circuit allowing direct connection to 3 V or 5 V bias and minimizing variations over temperature and process.

Functional Block Diagram

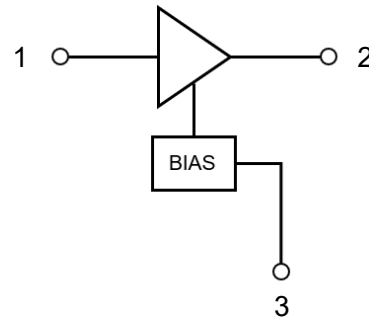

Pin Configuration¹

Pin #	Pin Name	Description
1	RF _{IN}	RF Input
2	RF _{OUT} / V _{DD}	RF Output / Drain Voltage
3	NC	No Connection

1. Bottom of die is RF and thermal ground.

Ordering Information

Part Number	Package
MAAM-011305-DIEPPR	Bare Die

* Restrictions on Hazardous Substances, compliant to current RoHS EU directive.

Broadband Low Noise Gain Block, Die, 16 dB 0.03 - 8 GHz



MAAM-011305-DIE

Rev. V1

Electrical Specifications: $V_{DD} = 5\text{ V}$, $+25^\circ\text{C}$, $Z_0 = 50\ \Omega$ (all data is GSG probed)

Parameter	Test Conditions	Units	Min.	Typ.	Max.
Gain	0.03 - 8 GHz	dB	14	16	—
Noise Figure	0.1 - 1.5 GHz 6.0 GHz 8.0 GHz	dB	—	1.6 2.5 3.6	—
Input Return Loss	0.03 - 8 GHz	dB	—	10	—
Output Return Loss	0.03 - 8 GHz	dB	—	10	—
Output IP3	$P_{IN} = -15\text{ dBm}$ per tone, 6 MHz spacing 0.03 - 3 GHz 6 GHz 8 GHz	dBm	—	37 32 27	—
Output IP2	$P_{IN} = -15\text{ dBm}$ per tone, 6 MHz spacing 0.03 - 3 GHz 6 GHz 8 GHz	dBm	—	44 50 52	—
Output P1dB	0.03 - 3 GHz 6 GHz 8 GHz	dBm	—	20 18 14	—
Current	I_{DD}	mA	—	66	85

Maximum Operating Ratings

Parameter	Maximum
RF Input Power CW	21 dBm
V_{DD}	6 V
I_{DQ}	100 mA
Operating Temperature	-40°C to +85°C
Junction Temperature ^{4,5}	+150°C

- Exceeding any one or combination of these limits may cause permanent damage to this device.
- MACOM does not recommend sustained operation near these survivability limits.
- Operating at nominal conditions with $T_J \leq 150^\circ\text{C}$ will ensure $MTTF > 1 \times 10^6$ hours.
- Junction Temperature (T_J) = $T_C + \Theta_{JC} * ((V * I) - (P_{OUT} - P_{IN}))$
Typical thermal resistance (Θ_{JC}) = 40°C/W
 - For $T_C = 25^\circ\text{C}$,
 $T_J = 39^\circ\text{C}$ @ 5 V, 66 mA
 - For $T_C = 85^\circ\text{C}$,
 $T_J = 100^\circ\text{C}$ @ 5 V, 75 mA

Absolute Maximum Ratings^{2,3}

Parameter	Absolute Maximum
RF Input Power CW	24 dBm
V_{DD}	7 V
Storage Temperature	-55°C to +150°C

Handling Procedures

Please observe the following precautions to avoid damage:

Static Sensitivity

Integrated Circuits are sensitive to electrostatic discharge (ESD) and can be damaged by static electricity. Proper ESD control techniques should be used when handling these HBM Class 1C devices.

Broadband Low Noise Gain Block, Die, 16 dB 0.03 - 8 GHz



MAAM-011305-DIE

Rev. V1

Typical Performance Curves @ 5 V / 66 mA, $Z_0 = 50 \Omega$ (all data is GSG probed)

Gain

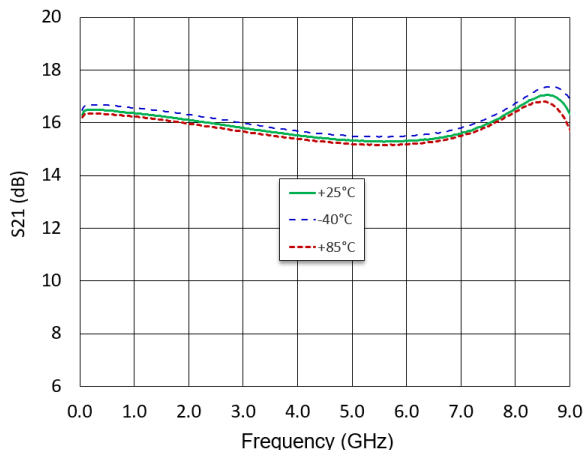

Gain to 12 GHz

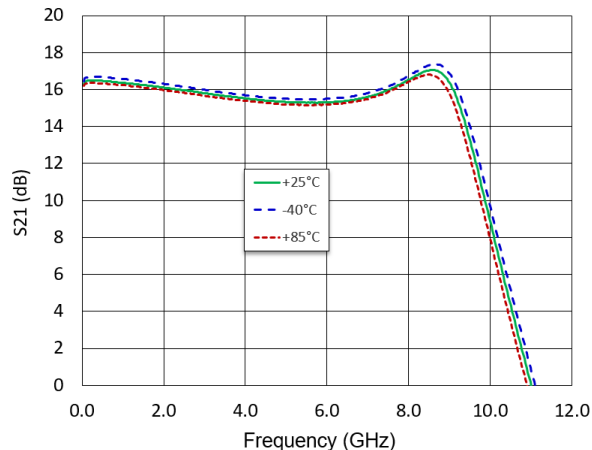

Input Return Loss

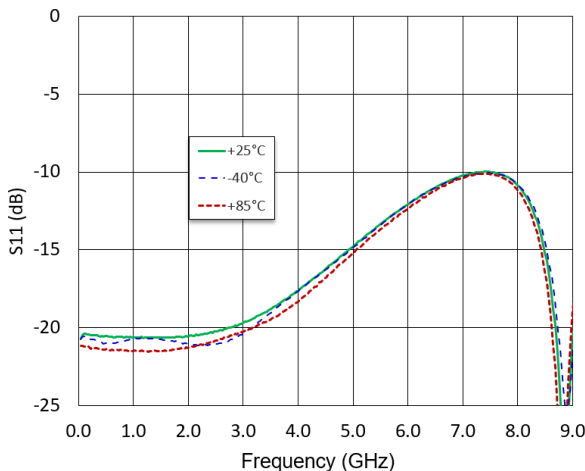

Output Return Loss

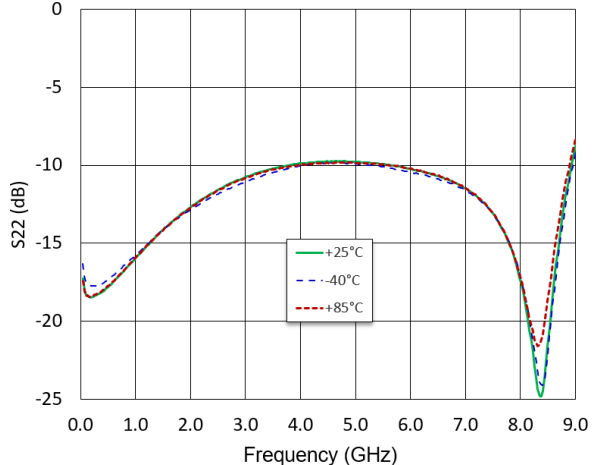

Reverse Isolation

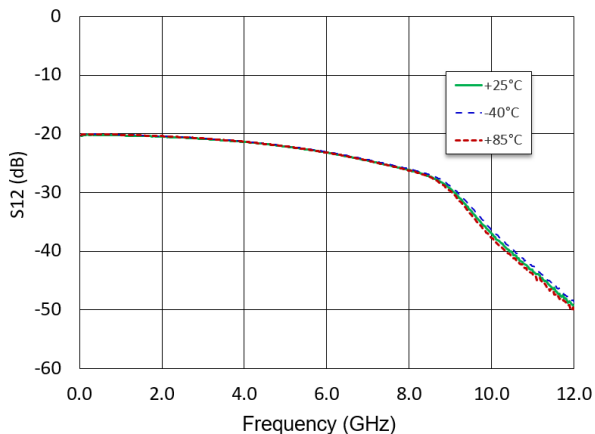

Noise Figure

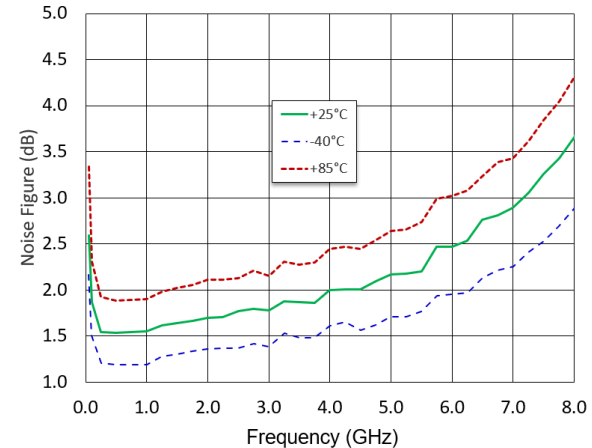

Broadband Low Noise Gain Block, Die, 16 dB 0.03 - 8 GHz



MAAM-011305-DIE

Rev. V1

Typical Performance Curves @ 5 V / 66 mA, $Z_0 = 50 \Omega$ (all data is GSG probed)

OIP3 at $P_{IN} = -15$ dBm/tone, 6MHz Spacing

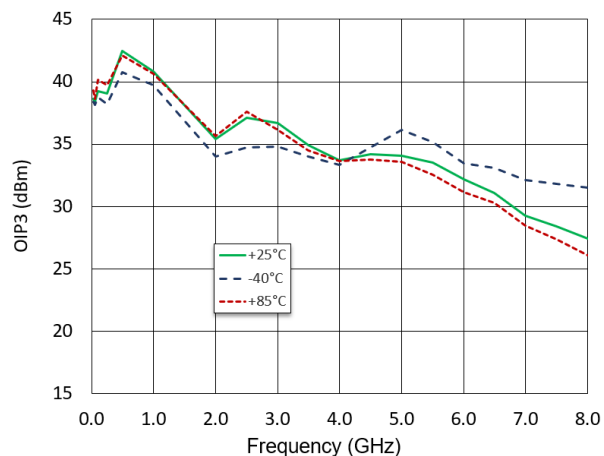

OIP2 at $P_{IN} = -15$ dBm/tone, 6MHz Spacing

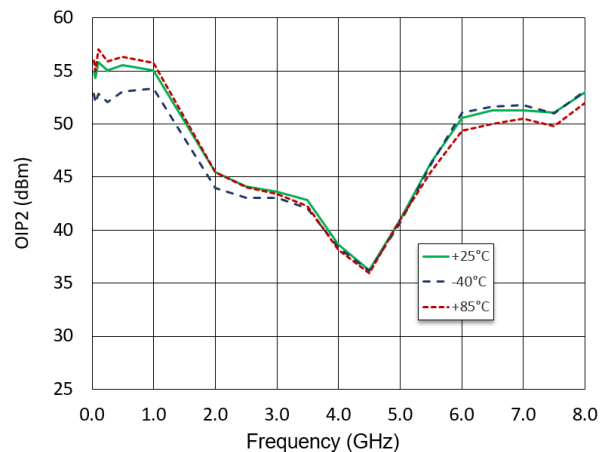

P1dB

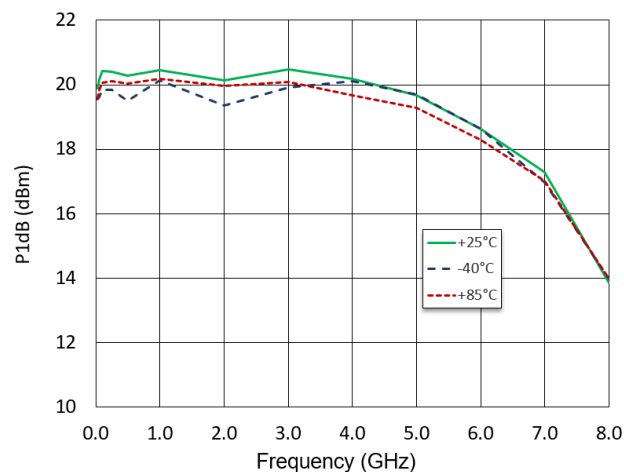

Typical Application Circuit

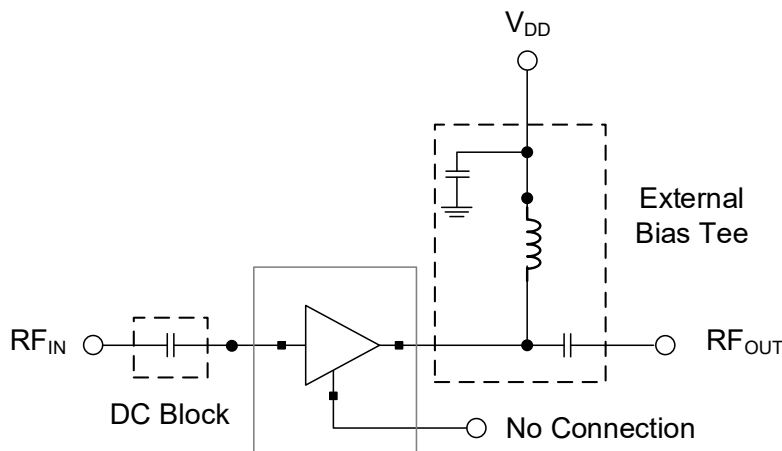

Die Outline^{6,7} (0.795 x 0.660 mm)

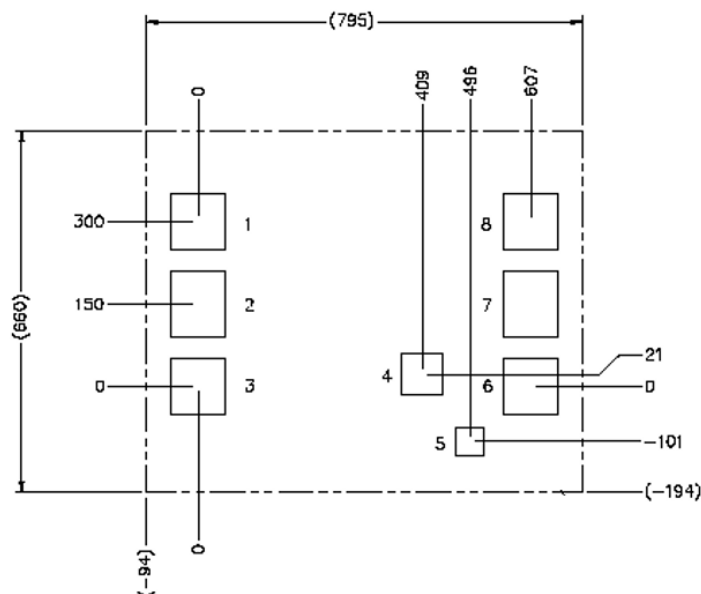

Bond Pad Dimensions (μm)

Pad #	Size (x)	Size (y)	Description
1, 3, 6, 8	100	100	GND
2	100	120	RF _{IN}
7	100	120	RF _{OUT} / V _{DD}
4	76	76	No Connection
5	50	50	GND

6. Dimensions are in microns.

7. GND bond pads 1, 3, 5, 6 and 8 are connected to the backside of the die through via holes. These bond pads do not require bond wires. Only pin 2 and 7 require bond wires.

Broadband Low Noise Gain Block, Die, 16 dB 0.03 - 8 GHz



MAAM-011305-DIE

Rev. V1

MACOM Technology Solutions Inc. ("MACOM"). All rights reserved.

These materials are provided in connection with MACOM's products as a service to its customers and may be used for informational purposes only. Except as provided in its Terms and Conditions of Sale or any separate agreement, MACOM assumes no liability or responsibility whatsoever, including for (i) errors or omissions in these materials; (ii) failure to update these materials; or (iii) conflicts or incompatibilities arising from future changes to specifications and product descriptions, which MACOM may make at any time, without notice. These materials grant no license, express or implied, to any intellectual property rights.

THESE MATERIALS ARE PROVIDED "AS IS" WITH NO WARRANTY OR LIABILITY, EXPRESS OR IMPLIED, RELATING TO SALE AND/OR USE OF MACOM PRODUCTS INCLUDING FITNESS FOR A PARTICULAR PURPOSE, MERCHANTABILITY, INFRINGEMENT OF INTELLECTUAL PROPERTY RIGHT, ACCURACY OR COMPLETENESS, OR SPECIAL, INDIRECT, INCIDENTAL, OR CONSEQUENTIAL DAMAGES WHICH MAY RESULT FROM USE OF THESE MATERIALS.

MACOM products are not intended for use in medical, lifesaving or life sustaining applications. MACOM customers using or selling MACOM products for use in such applications do so at their own risk and agree to fully indemnify MACOM for any damages resulting from such improper use or sale.