

### Features

- Non-Magnetic Package (4 mm)
- Noise Figure: 0.6 dB
- Gain: 26 dB
- Input Resistance:  $2.5 \Omega$
- Output Impedance:  $50 \Omega$
- Single Voltage Bias: 3 V
- Integrated Active Bias Circuit
- Current Adjustable 30 - 80 mA
- RoHS\* Compliant

### Applications

- MRI Applications

### Description

The MAAL-011204 is a high dynamic range, single stage MMIC LNA. With external matching networks it exhibits excellent low noise performance, low input impedance and high gain characteristics suitable for 1.5T and 3.0T applications.

This low noise amplifier has an integrated active bias circuit allowing direct connection to 3 V or 5 V bias and minimizing variations over temperature and process. The bias current is set by an external resistor, so the user can customize the power consumption to fit the application.

### Functional Block Diagram

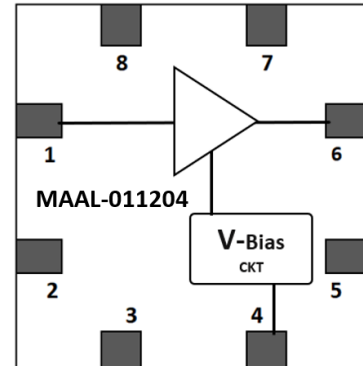

### Pin Configuration<sup>1,2</sup>

Pin #	Pin Name	Description
1	RF <sub>IN</sub>	RF Input
2, 3, 5, 7, 8	N/C	No Connection
4	V <sub>BIAS</sub>	Bias Voltage
6	RF <sub>OUT</sub> / V <sub>DD</sub>	RF Output / Drain Voltage

1. MACOM recommends connecting unused package pins to ground.
2. The exposed pad centered on the package bottom must be connected to RF, DC and thermal ground.

### Ordering Information

Part Number	Package
MAAL-011204-TR1000	1000 piece reel
MAAL-011204-TR3000	3000 piece reel
MAAL-011204-001SMB	3.0 T Sample Board
MAAL-011204-002SMB	1.5 T Sample Board

<sup>1</sup> \* Restrictions on Hazardous Substances, compliant to current RoHS EU directive.

**Electrical Specifications<sup>3</sup>:** **$V_{DD} = 3\text{ V}$ ,  $+25^{\circ}\text{C}$ ,  $Z_{LOAD}$  &  $Z_{SOURCE} = 50\ \Omega$ , tuned for 1.5T (FO = 63.87 MHz)**

Parameter	Test Conditions	Units	Min.	Typ.	Max.
Bandwidth	Centered at 63.87 MHz	MHz	—	1	—
Noise Figure	-	dB	—	0.6	—
Gain	-	dB	—	28	—
Input Reflection Coefficient <sup>3</sup>	-	—	—	0.69	—
Input Impedance	Real $Z_{in}$ Imaginary $Z_{in}$	Ohms	—	+2 -1	—
Output Return Loss <sup>3</sup>	-	dB	—	18	—
Output IP3	$P_{OUT} = 0\text{ dBm}$ per tone, 1 MHz & 100 KHz spacing	dBm	—	28	—
Output P1dB	-	dBm	—	10.5	—
Total Current	$I_{DD}$	mA	—	37	—

**Electrical Specifications<sup>3</sup>:** **$V_{DD} = 3\text{ V}$ ,  $+25^{\circ}\text{C}$ ,  $Z_{LOAD}$  &  $Z_{SOURCE} = 50\ \Omega$ , tuned for 3T (FO = 127.74 MHz)**

Parameter	Test Conditions	Units	Min.	Typ.	Max.
Bandwidth	Centered at 127.74 MHz	MHz	—	1	—
Noise Figure	-	dB	—	0.6	—
Gain	-	dB	25	27	—
Input Reflection Coefficient <sup>3</sup>	-	—	—	0.85	—
Input Impedance	Real $Z_{in}$ Imaginary $Z_{in}$	Ohms	—	2.5 2.5	4 —
Output Return Loss <sup>3</sup>	-	dB	—	20	—
Output IP3	$P_{OUT} = 0\text{ dBm}$ per tone, 1 MHz & 100 KHz spacing	dBm	—	25.4	—
Output P1dB	-	dBm	—	11.5	—
Total Current	$I_{DD}$	mA	—	37	50

3. Using external matching components. Refer to Application section.

## Maximum Operating Limits

Parameter	Maximum
RF Input Power CW	-3 dBm
V <sub>DD</sub>	5.5 V
V <sub>BIAS</sub>	5 V
Operating Temperature	-40°C to +85°C
Junction Temperature <sup>4,5</sup>	+150°C

4. Operating at nominal conditions with  $T_J \leq 150^\circ\text{C}$  will ensure  $\text{MTTF} > 1 \times 10^6$  hours.
5. Junction Temperature ( $T_J$ ) =  $T_C + \Theta_{JC} * ((V * I) - (P_{OUT} - P_{IN}))$   
 Typical thermal resistance ( $\Theta_{JC}$ ) = 83°C/W
  - a) For  $T_C = +25^\circ\text{C}$ ,  
 $T_J = 33^\circ\text{C}$  @ 3 V, 0.05 A,  $P_{OUT} = 17.5$  dBm,  $P_{IN} = -4.5$  dBm
  - b) For  $T_C = +85^\circ\text{C}$ ,  
 $T_J = 93^\circ\text{C}$  @ 3 V, 0.05 A,  $P_{OUT} = 17.5$  dBm,  $P_{IN} = -4.5$  dBm

## Absolute Maximum Ratings<sup>6,7</sup>

Parameter	Absolute Maximum
RF Input Power CW	19 dBm
V <sub>DD</sub>	6 V
V <sub>BIAS</sub>	5 V
Storage Temperature	-55°C to +150°C

6. Exceeding any one or combination of these limits may cause permanent damage to this device.
7. MACOM does not recommend sustained operation near these survivability limits.

## Application Schematic

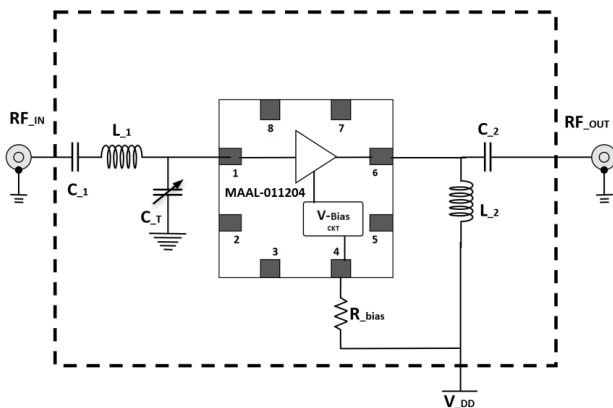

## Handling Procedures

Please observe the following precautions to avoid damage:

### Static Sensitivity

Gallium Arsenide Integrated Circuits are sensitive to electrostatic discharge (ESD) and can be damaged by static electricity. Proper ESD control techniques should be used when handling these Class 0A HBM and Class C2A CDM devices.

## Tuned Circuit Board for 1.5T and 3T Applications

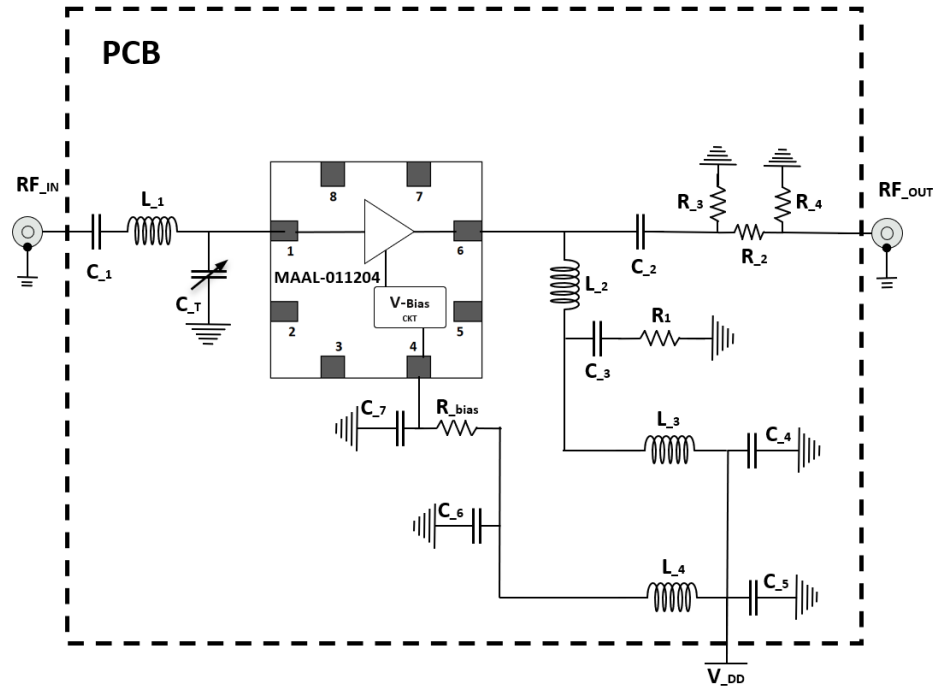

### Component Values for 1.5T and 3T

Component	3T Value	1.5T Value	%	Case Size	Vendor
C1	330 pF	470 pF	+/-2	0603	Vishay Vitramon, non-magnetic (COG)
C2	22 pF	24 pF	+/-2	0402	Vishay Vitramon, non-magnetic (COG)
CT	5-30 pF	8-40 pF	-	3mm	PPI 46 Series 3mm Surface Mount
C3	330 pF	470 pF	+/-2	0603	Vishay Vitramon, non-magnetic (COG)
C4, C5	0.01 $\mu$ F	0.01 $\mu$ F	+/-5	0603	Vishay Vitramon, non-magnetic (XR7)
C6, C7	0.1 $\mu$ F	0.1 $\mu$ F	+/-5	0603	Vishay Vitramon, non-magnetic (XR7)
L1	78 nH	120 nH	+/-2	0603	CoilCraft 0603HP Series (1608)
L2	78 nH	270 nH	+/-2	0603	CoilCraft 0603HP Series (1608)
L3, L4	4500 nH	4500 nH	+/-5	1008	CoilCraft 1008HP Series (2520)
RBIAS	1250 $\Omega$	1250 $\Omega$	+/-2	0402	Vishay PNM Dale Thin Film, non-magnetic
R1	44 $\Omega$	40 $\Omega$	+/-5	0402	Vishay PNM Dale Thin Film, non-magnetic
R2	6 $\Omega$	12 $\Omega$	+/-5	0402	Vishay PNM Dale Thin Film, non-magnetic
R3, R4	870 $\Omega$	440 $\Omega$	+/-5	0402	Vishay PNM Dale Thin Film, non-magnetic

Substrate recommended:

- RO4350, 0.010" CORE
- 1/2 oz. Cu

Typical 1.5T RF Performance (63.87 MHz)

Gain

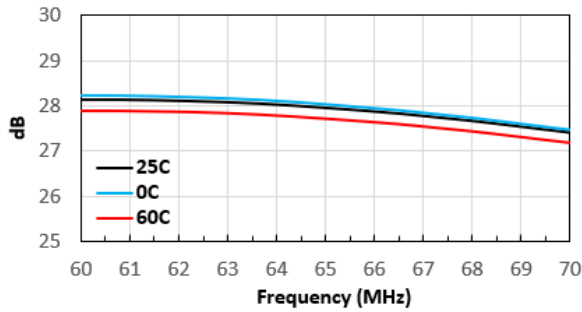

Real Zin

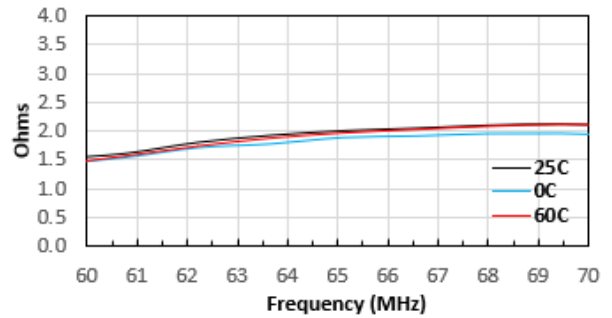

Output Return Loss

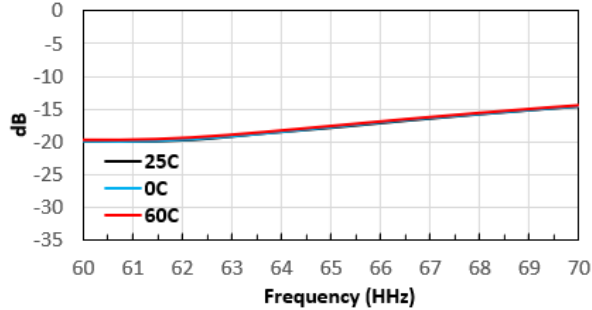

Imaginary Zin

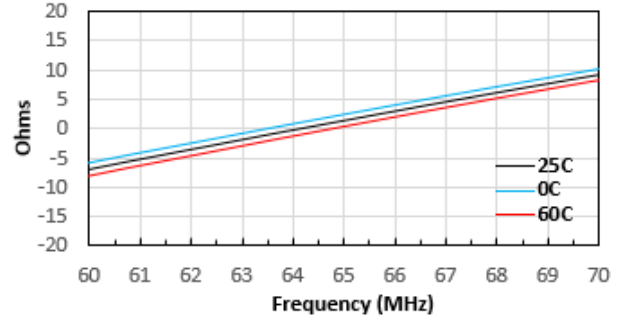

Input Return Loss Phase

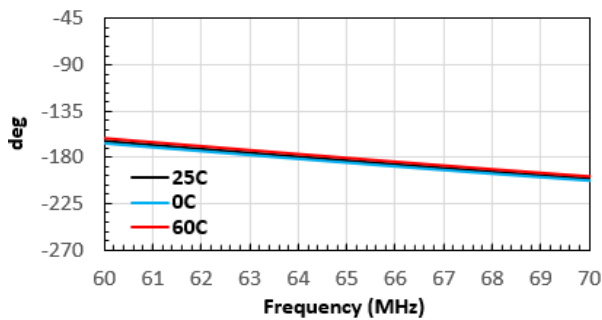

Noise Figure

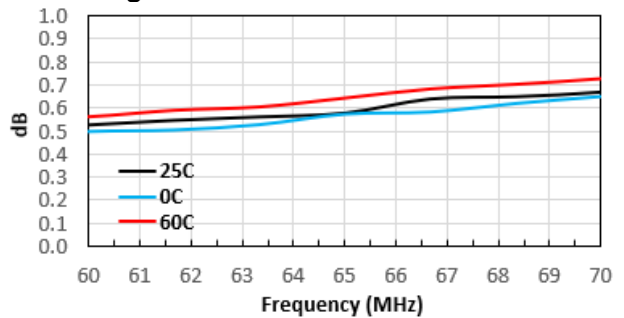

## Typical 3T RF Performance (127.74 MHz)

### Gain

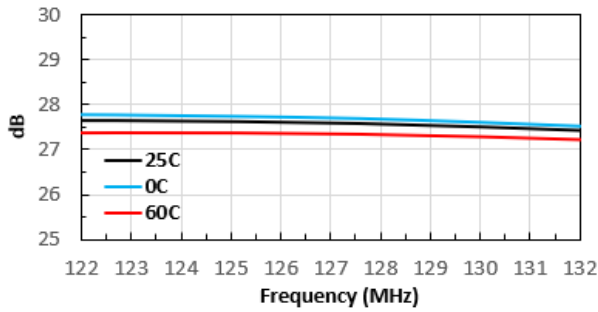

### Real Zin

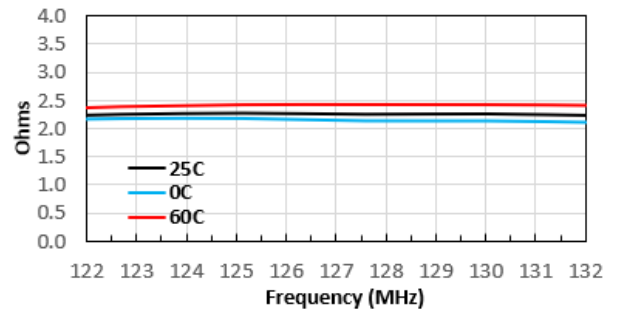

### Output Return Loss

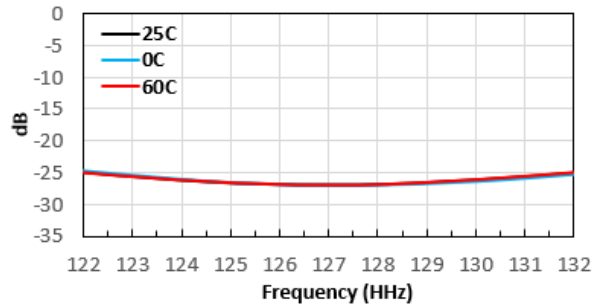

### Imaginary Zin

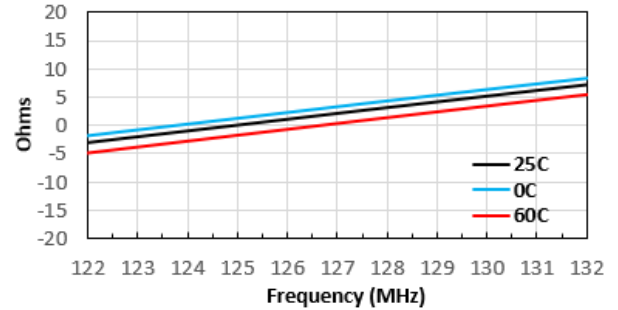

### Input Return Loss Phase

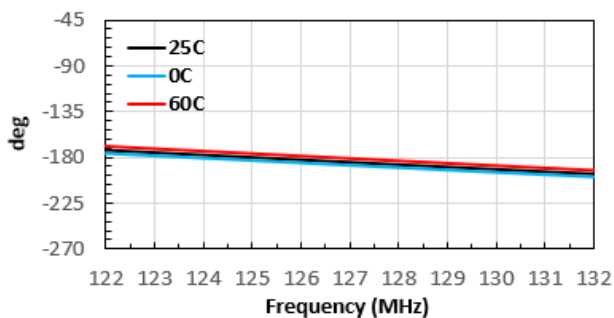

### Noise Figure

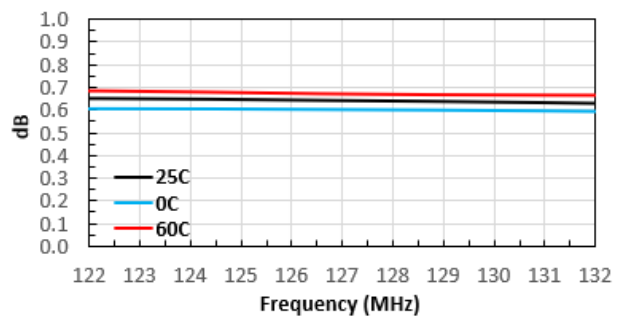

Non-Magnetic 4 mm, 8-Lead SMT Package

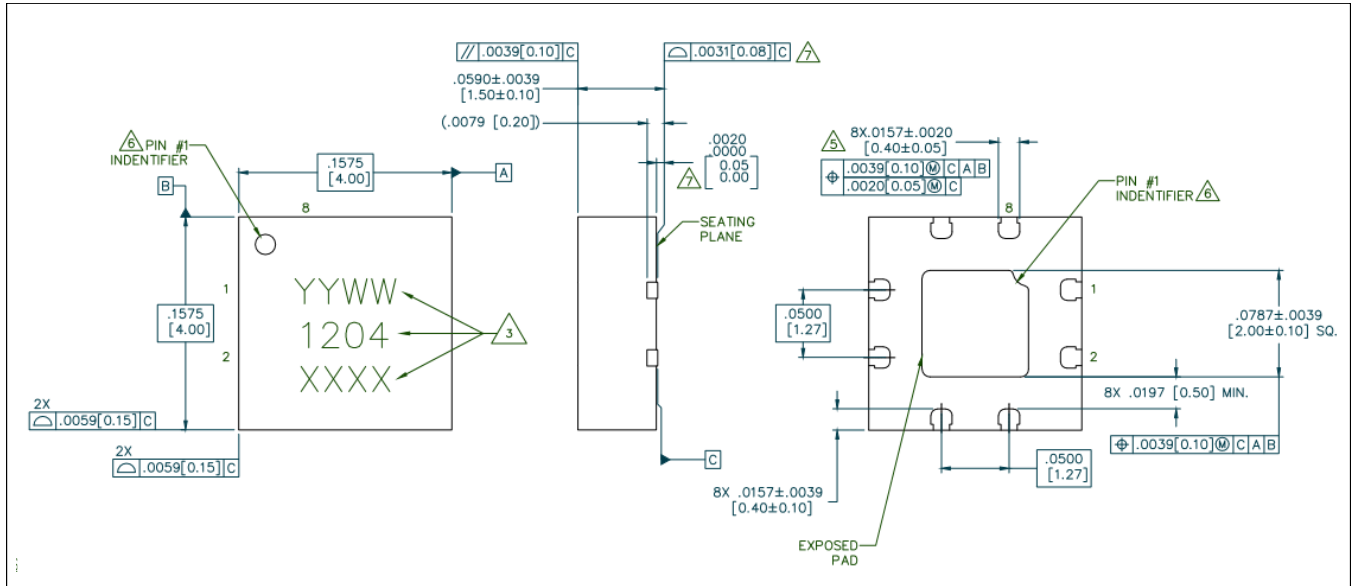

MACOM Technology Solutions Inc. ("MACOM"). All rights reserved.

These materials are provided in connection with MACOM's products as a service to its customers and may be used for informational purposes only. Except as provided in its Terms and Conditions of Sale or any separate agreement, MACOM assumes no liability or responsibility whatsoever, including for (i) errors or omissions in these materials; (ii) failure to update these materials; or (iii) conflicts or incompatibilities arising from future changes to specifications and product descriptions, which MACOM may make at any time, without notice. These materials grant no license, express or implied, to any intellectual property rights.

THESE MATERIALS ARE PROVIDED "AS IS" WITH NO WARRANTY OR LIABILITY, EXPRESS OR IMPLIED, RELATING TO SALE AND/OR USE OF MACOM PRODUCTS INCLUDING FITNESS FOR A PARTICULAR PURPOSE, MERCHANTABILITY, INFRINGEMENT OF INTELLECTUAL PROPERTY RIGHT, ACCURACY OR COMPLETENESS, OR SPECIAL, INDIRECT, INCIDENTAL, OR CONSEQUENTIAL DAMAGES WHICH MAY RESULT FROM USE OF THESE MATERIALS.

MACOM products are not intended for use in medical, lifesaving or life sustaining applications. MACOM customers using or selling MACOM products for use in such applications do so at their own risk and agree to fully indemnify MACOM for any damages resulting from such improper use or sale.