

Low Phase Noise Amplifier

2 - 30 GHz



MAAL-011158

Rev. V1

Features

- Phase Noise: -172 dBc/Hz @ 10 kHz
- Gain: 12 dB
- P_{SAT} : +24 dBm
- Bias Voltage: $V_{CC} = +6 V$
- Bias Current: $I_{CQ} = 135 mA$
- 50 Ω Matched Input and Output
- Positive Voltage Only
- Lead-Free 5 mm AQFN 32-lead Package
- RoHS* Compliant

Applications

- Radar
- Electronic Countermeasures
- Test and Measurement
- Microwave Communication Systems

Description

The MAAL-011158 is an easy to use low phase noise amplifier assembled in a lead-free 5 mm 32-lead air cavity QFN plastic package. It operates from 2 - 30 GHz and provides -172 dBc/Hz phase noise, 12 dB gain and 24 dBm P_{SAT} . The input and output are fully matched to 50 Ω with typical return loss >14 dB.

This product is fabricated using a GaAs HBT process which features full passivation for enhanced reliability.

Ordering Information^{1,2}

Part Number	Package
MAAL-011158-TR0100	100 piece reel
MAAL-011158-SMB	Sample Board

1. Reference Application Note M513 for reel size information.
2. All sample boards include 3 loose parts.

Functional Schematic

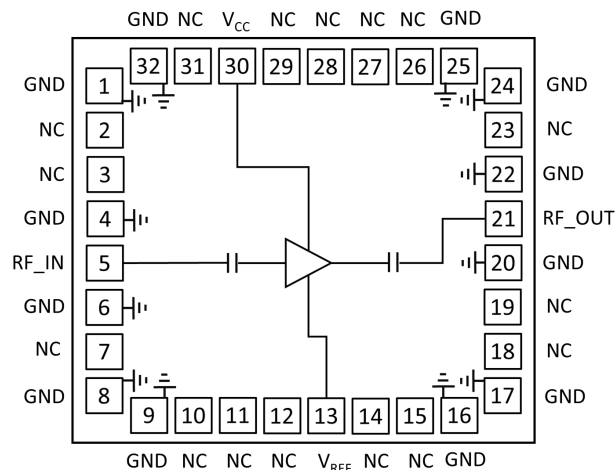

Pin Configuration³

Pad #	Pad Name	Description
1,4,6,8,9,16,17,20,22,24,25,32	GND	Ground
2,3,7,10,11,12,14,15,18,19,23,26,27,28,29,31	NC ⁴	No Connection
5	RF_IN	RF Input
13	V_{REF}	Reference Voltage
21	RF_OUT	RF Output
30	V_{CC}	Collector Supply

3. Backside of die must be connected to RF, DC and thermal ground.
4. It is recommended that these pins are grounded on the application PCB.

* Restrictions on Hazardous Substances, compliant to current RoHS EU directive.

Electrical Specifications: Freq. = 2 - 30 GHz, T_A = +25°C, V_{CC} = 6 V, Z₀ = 50 Ω

Parameter	Test Conditions	Units	Min.	Typ.	Max.
Gain	P _{IN} = -10 dBm, 6 GHz P _{IN} = -10 dBm, 18 GHz P _{IN} = -10 dBm, 28 GHz	dB	10.0 9.5 8.5	12.0 11.5 10.5	—
Gain Flatness	—	dB	—	±1	—
Gain Variation over Temperature	—	dB/°C	—	0.011	—
Output Power	P _{IN} = +13 dBm, 6 GHz P _{IN} = +10 dBm, 18 GHz P _{IN} = +10 dBm, 28 GHz	dBm	22.0 18.0 17.5	24.0 20.0 19.5	—
Noise Figure	—	dB	—	5.0	—
Input Return Loss	—	dB	—	15	—
Output Return Loss	—	dB	—	10	—
P1dB	16 GHz	dBm	—	21	—
P _{SAT}	16 GHz	dBm	—	24	—
OIP3	16 GHz, -10 dBm P _{IN} per tone	dBm	—	32.5	—
Phase Noise	10 GHz, P _{SAT} 100 Hz 1 kHz 10 kHz 1 MHz	dBc/Hz	—	-148 -164 -172 -178	—
I _{cc}	—	mA	—	135	—

Absolute Maximum Ratings^{5,6}

Parameter	Absolute Maximum
Input Power	19 dBm
V _{CC}	7.5 V
I _{CC}	350 mA
Junction Temperature ^{7,8}	+130°C
Operating Temperature	-40°C to +85°C
Storage Temperature	-65°C to +125°C

5. Exceeding any one or combination of these limits may cause permanent damage to this device.
6. MACOM does not recommend sustained operation near these survivability limits.
7. Operating at nominal conditions with T_J ≤ +130°C will ensure MTTF > 1 x 10⁶ hours.
8. Junction Temperature (T_J) = T_C + Θ_{Jc} * (V * I)
Typical thermal resistance (Θ_{Jc}) = 17.4 °C/W.
 - a) For T_C = +25°C,
T_J = 61.5°C @ 7.5 V, 280 mA
 - b) For T_C = +85°C,
T_J = 121.5°C @ 7.5 V, 280 mA

Maximum Operating Conditions

Parameter	Maximum
Input Power	17 dBm
V _{CC}	7 V
I _{CC}	280 mA
Junction Temperature	+130°C
Operating Temperature	-40°C to +85°C
Storage Temperature	-65°C to +125°C

Handling Procedures

Please observe the following precautions to avoid damage:

Static Sensitivity

These electronic devices are sensitive to electrostatic discharge (ESD) and can be damaged by static electricity. Proper ESD control techniques should be used when handling these HBM Class 1A, 250 V devices.

Pad Configuration and Functional Descriptions

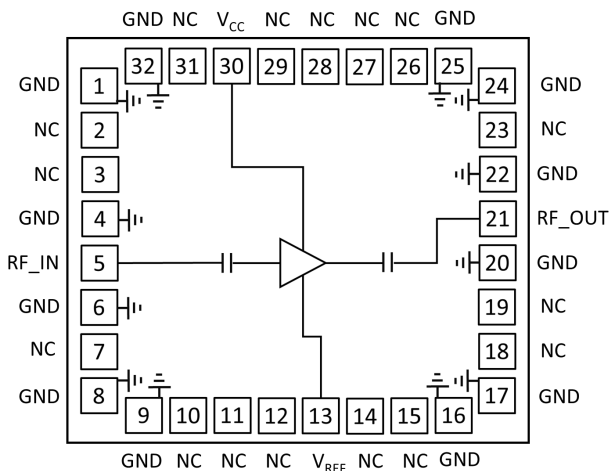

Pad #	Pin Name	Description
1,4,6,8,9,16,17,20,22,24,25,32	GND	These pins are internally connected to ground.
2,3,7,10,11,12,14,15,18,19,23,26,27,28,29,31	NC	These pins are not internally connected (i.e. open circuit). It is recommended that these are connected to ground on the application PCB.
5	RF_IN	RF Signal Input. This pin is matched to 50 Ω and is AC coupled.
13	V _{REF}	This is the reference voltage used to set the quiescent collector current. External bypass capacitors are required as described in the applications schematic
21	RF_OUT	RF Signal Output. This pad is matched to 50 Ω and is AC coupled
30	V _{CC}	Collector bias for the amplifier. External bypass capacitors are required as described in the applications schematic

Interface Schematics

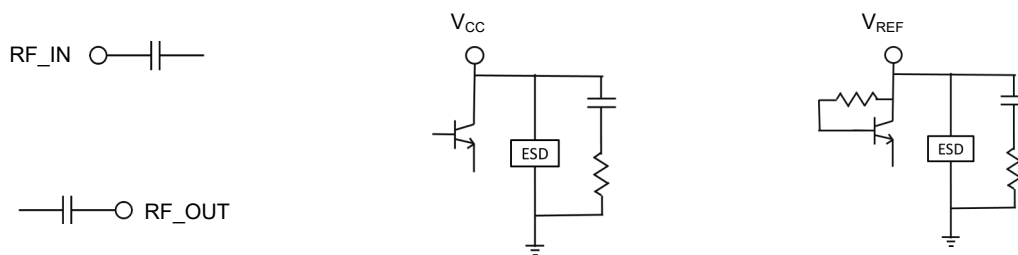

Low Phase Noise Amplifier 2 - 30 GHz



MAAL-011158

Rev. V1

Evaluation Board Layout

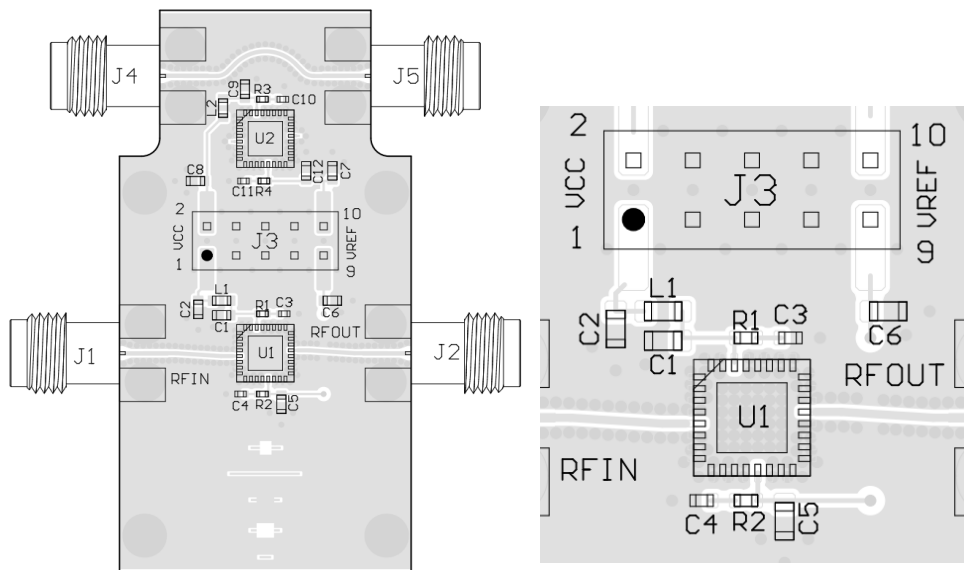

PCB DESIGN NOTES:

- RO4003C, 8 mil thick
- 1/2 copper
- Plating: solderable gold
- RF Trace: 14.0 mil width
- RF Space: 6.5 mil space
- 370 hr. or FR-406 backing
4 layers, total thickness 0.062"

Evaluation Board Schematic

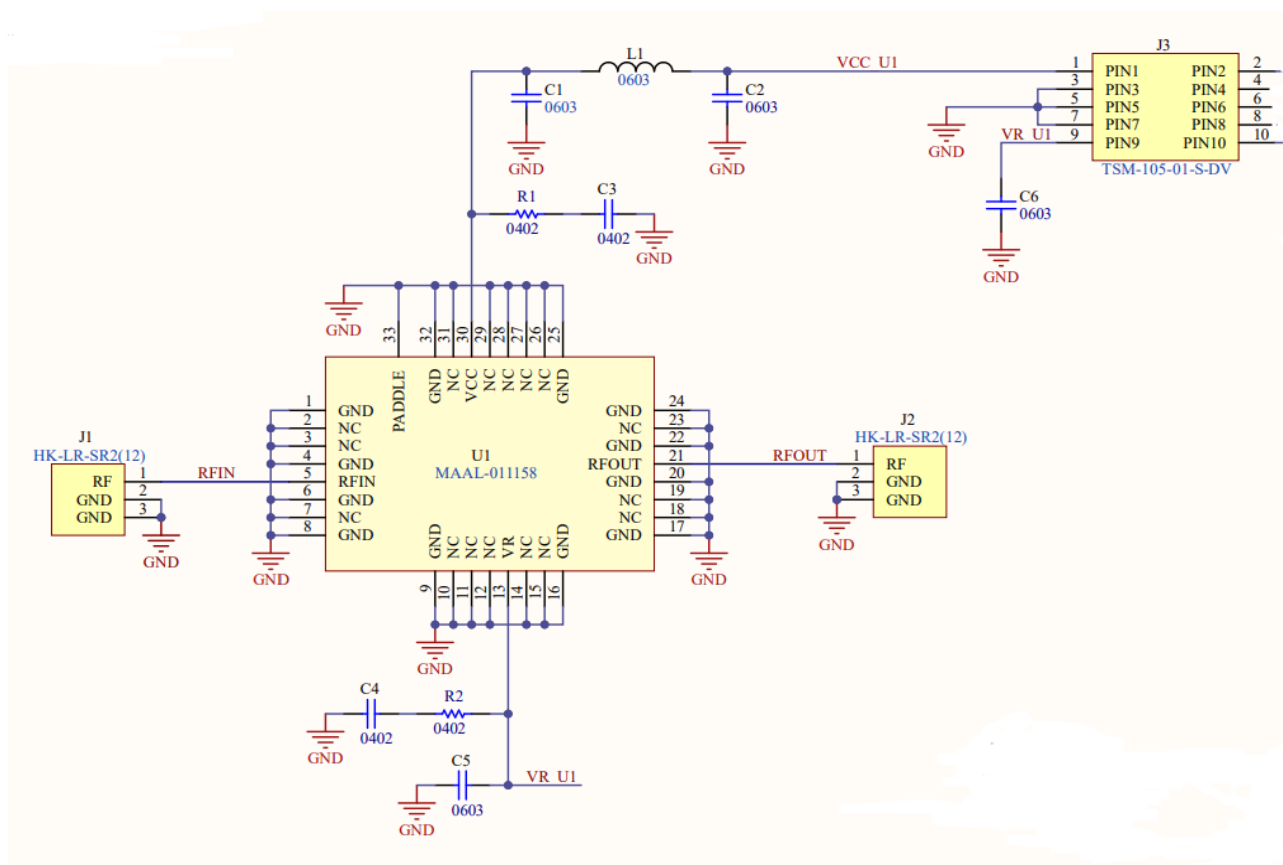

4

MACOM Technology Solutions Inc. (MACOM) and its affiliates reserve the right to make changes to the product(s) or information contained herein without notice. Visit www.macom.com for additional data sheets and product information.

For further information and support please visit:
<https://www.macom.com/support>

DC-0030533

Parts List

Part	Value	Case Style
C2, C6	1 μ F	0603
C1, C5	0.1 μ F	0603
C3, C4	100 pF	0402
R1, R2	10 Ω	0402
L1	10 nH	0603
C7-C11,R3,R4,L2,U2	DNI	DNI

Evaluation Board Component Positioning

The 100 pF capacitors should be placed as close to the amplifier as practically possible. For the larger 0.1 μ F capacitors proximity to the MMIC die is less important. The circuit is not sensitive to the positioning of the 1.0 μ F capacitors however these should be on the same PCB as the rest of the biasing components.

To ensure proper grounding the number of ground vias under the device should be maximized (within practical limits imposed by the PCB vendor).

Biasing Conditions

Recommended biasing conditions are $V_{CC} = 6$ V, $I_{CC} = 135$ mA (controlled with V_{REF}). The collector bias voltage range is 4 to 6 V, and the quiescent collector current biasing range is 125 to 145 mA.

Operation

To turn-on:

1. Apply +6 V to V_{CC}
2. Starting at 0 V, adjust V_{REF} for target I_{CC} (+2 V typical)

To turn-off:

1. Set V_{REF} to 0 V
2. Set V_{CC} to 0 V

Low Phase Noise Amplifier

2 - 30 GHz



MAAL-011158

Rev. V1

Typical Performance Curves: $V_{CC} = 6\text{ V}$, $I_{CC} = 135\text{ mA}$

Gain

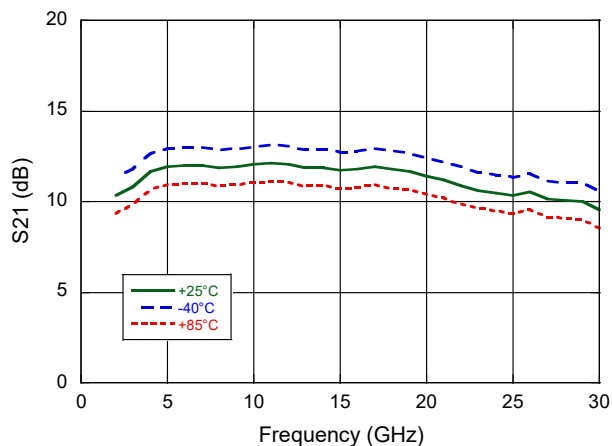

Input Return Loss

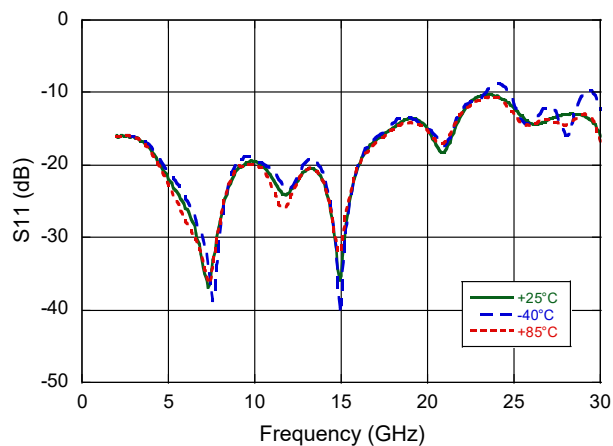

Output Return Loss

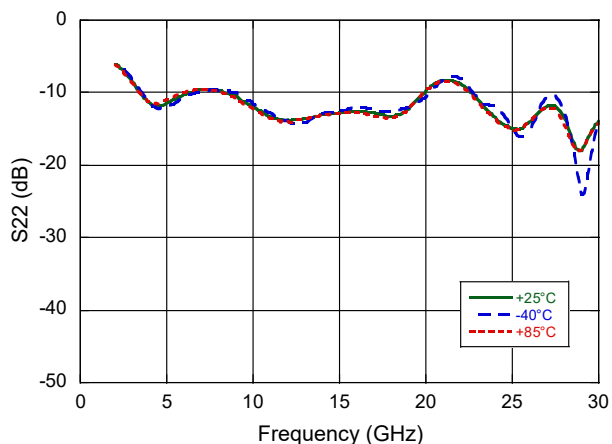

Reverse Isolation

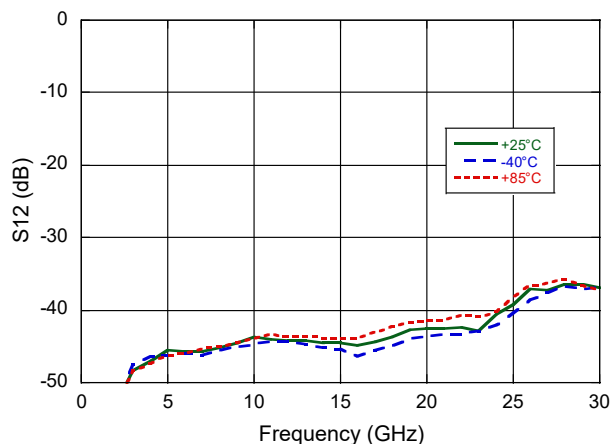

P1dB

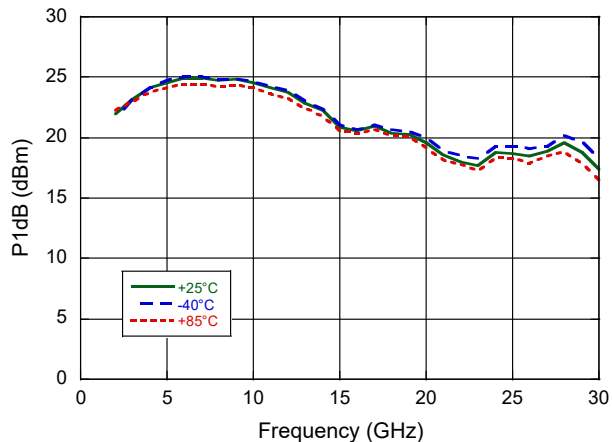

P_{SAT}

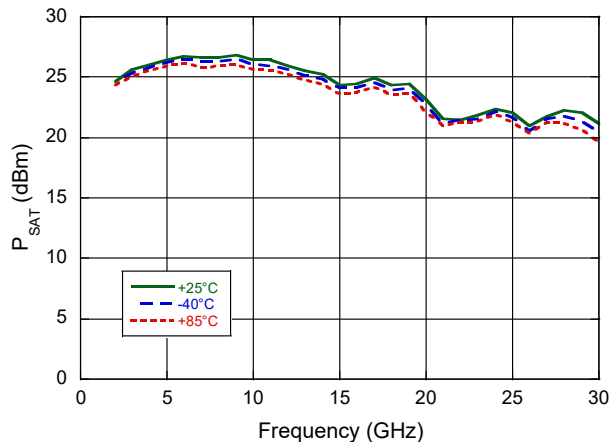

Low Phase Noise Amplifier

2 - 30 GHz



MAAL-011158

Rev. V1

Typical Performance Curves: $I_{CC} = 135 \text{ mA}$, $+25^\circ\text{C}$

Gain

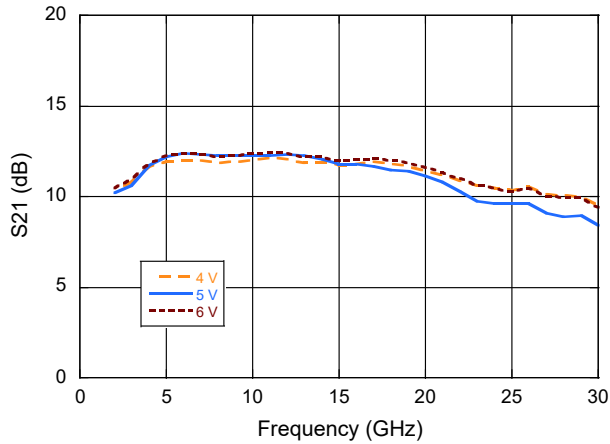

Input Return Loss

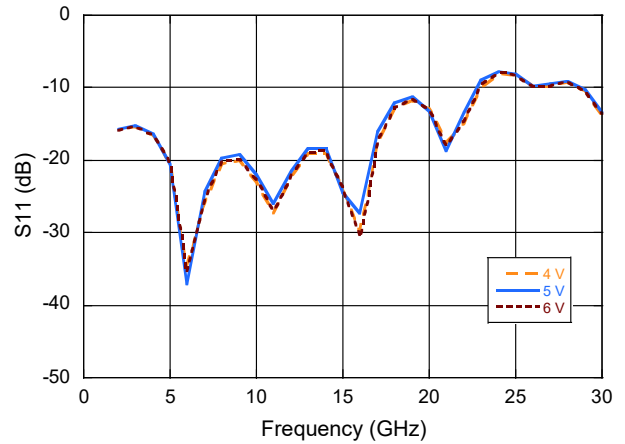

Output Return Loss

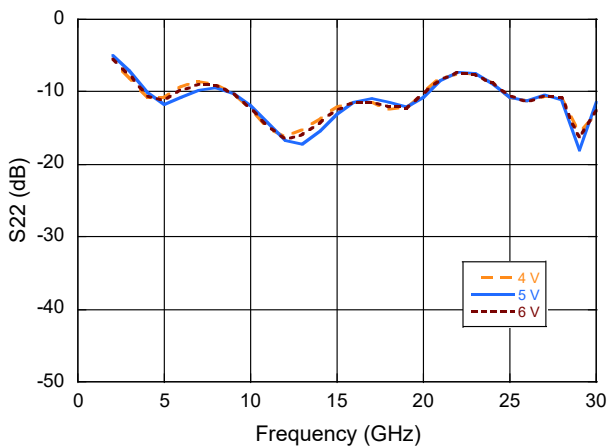

Reverse Isolation

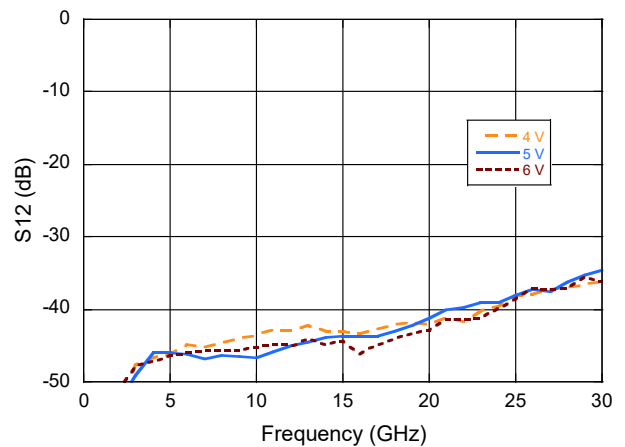

P1dB

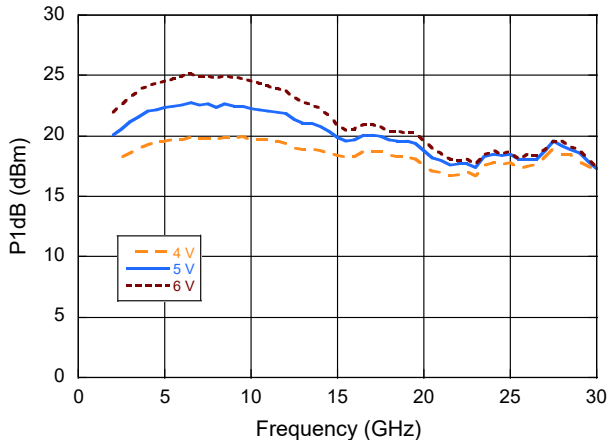

P_{SAT}

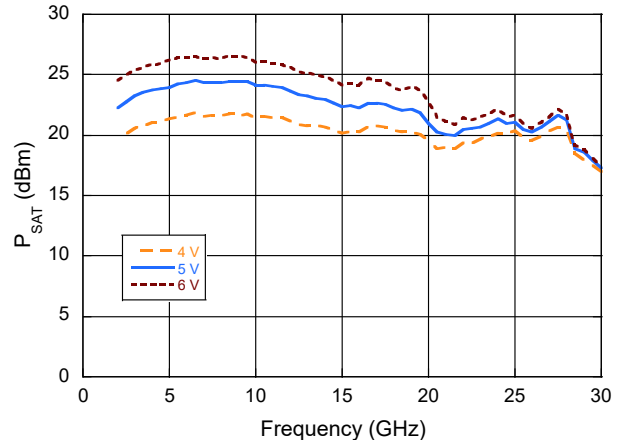

Low Phase Noise Amplifier

2 - 30 GHz



MAAL-011158

Rev. V1

Typical Performance Curves: $V_{CC} = 6\text{ V}$, $+25^\circ\text{C}$

Gain

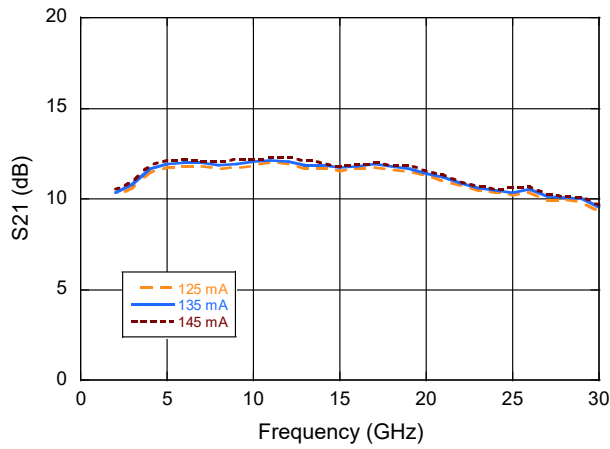

Input Return Loss

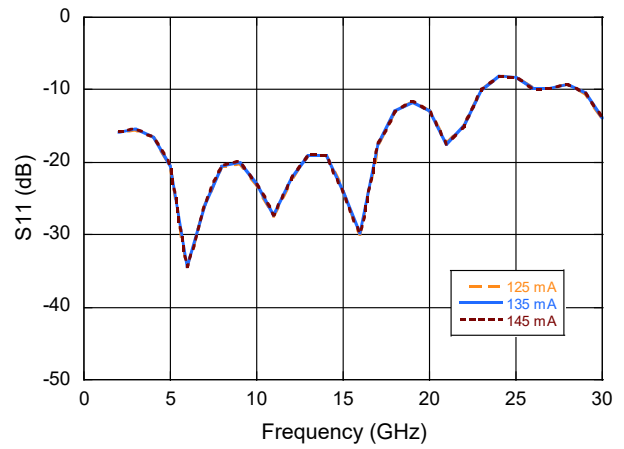

Output Return Loss

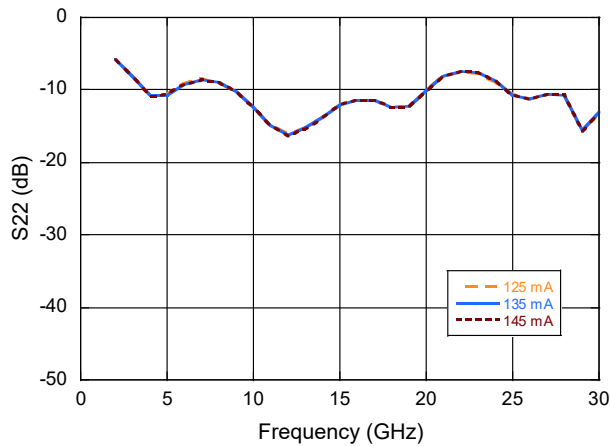

Reverse Isolation

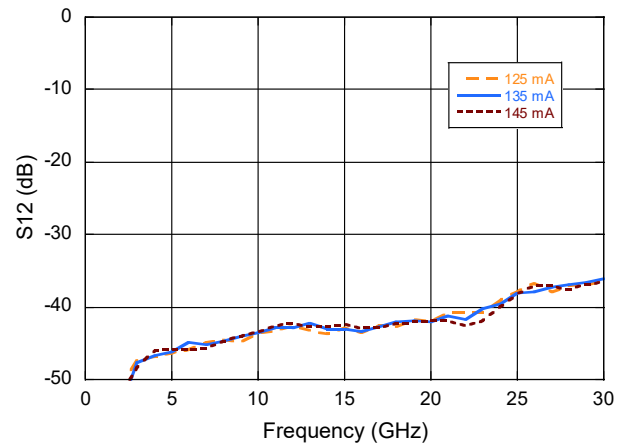

P1dB

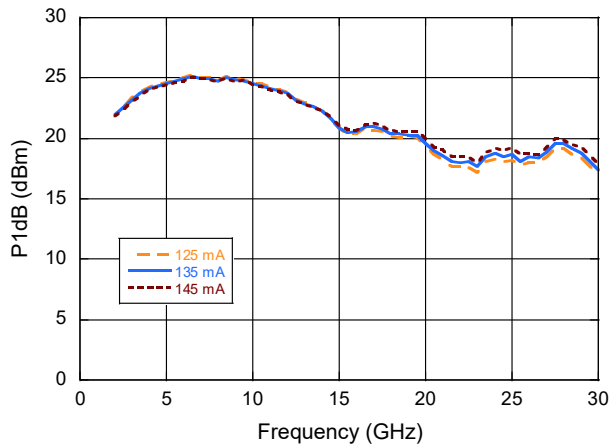

PsAT

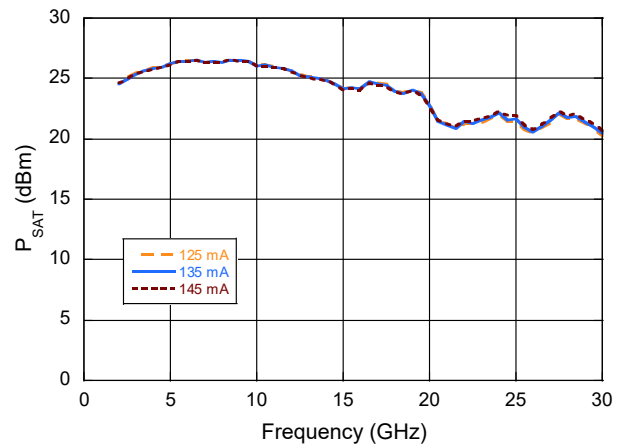

Low Phase Noise Amplifier

2 - 30 GHz



MAAL-011158

Rev. V1

Typical Performance Curves: $V_{CC} = 6\text{ V}$, $I_{CC} = 135\text{ mA}$, $+25^\circ\text{C}$

Output IP3
(10 MHz Tone Spacing, $P_{IN} = -5\text{ dBm}$ per tone)

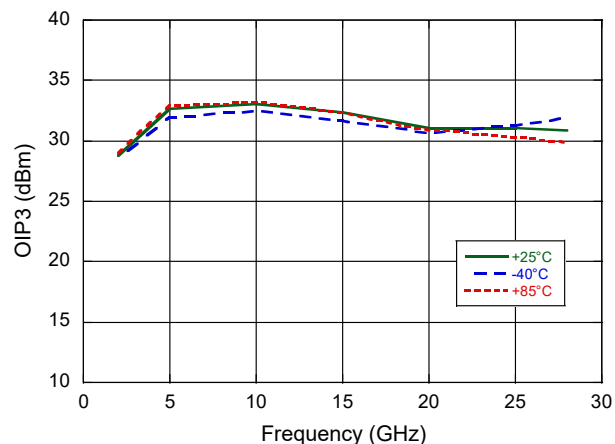

Noise Figure

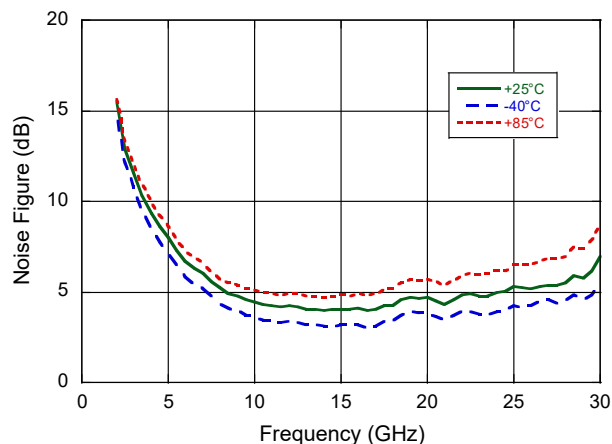

Output IP3
(10 MHz Tone Spacing, $P_{IN} = -5\text{ dBm}$ per tone)

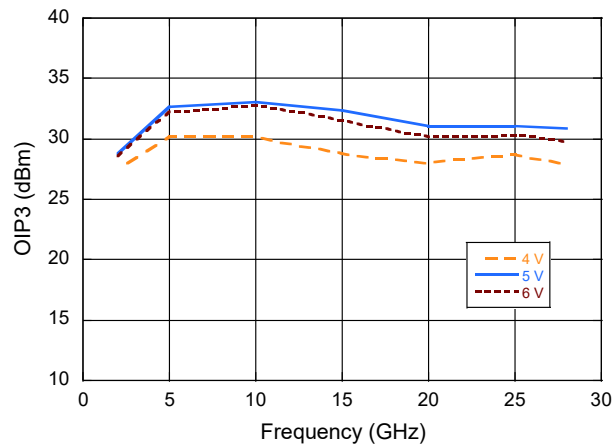

Noise Figure

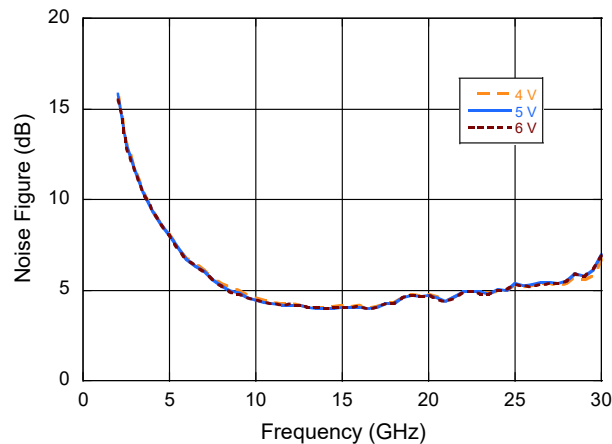

Output IP3
(10 MHz Tone Spacing, $P_{IN} = -5\text{ dBm}$ per tone)

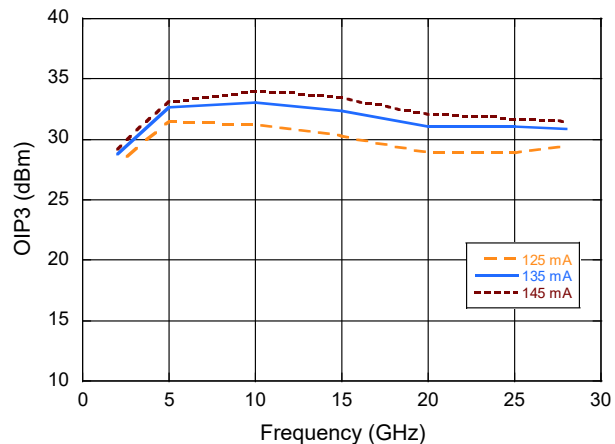

Noise Figure

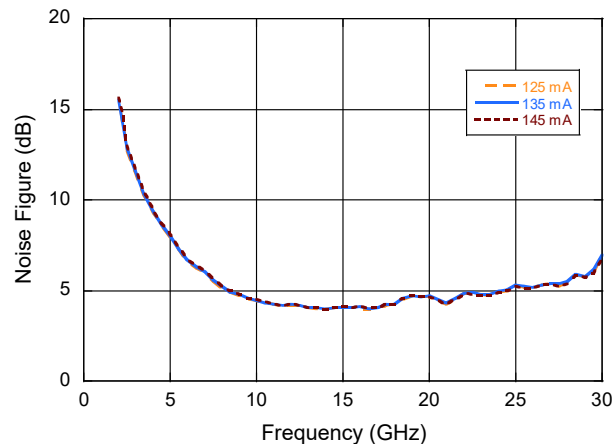

Low Phase Noise Amplifier

2 - 30 GHz



MAAL-011158

Rev. V1

Typical Performance Curves⁶: $I_{CC} = 135 \text{ mA}$, 6 V , $+25^\circ\text{C}$

Phase Noise @ 4 GHz, P1dB

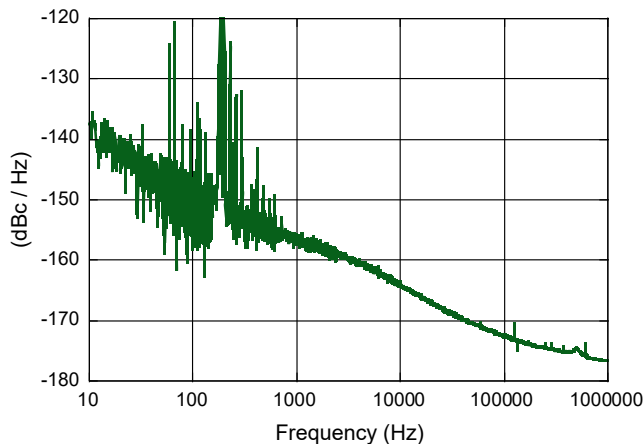

Phase Noise @ 4 GHz, P4dB

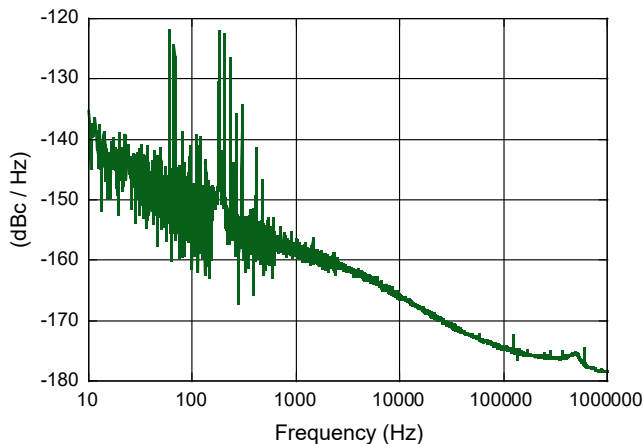

Phase Noise @ 10 GHz, P1dB

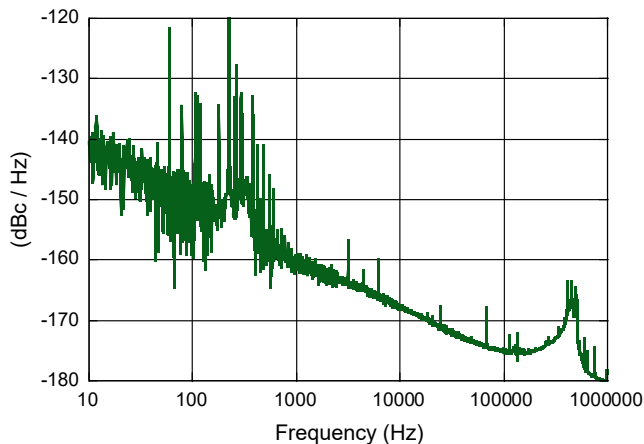

Phase Noise @ 10 GHz, P3dB

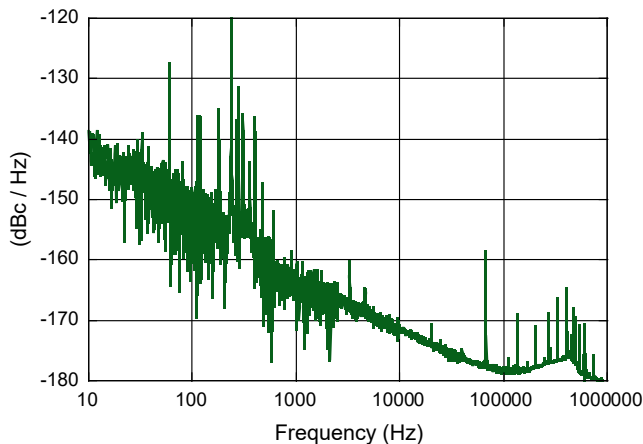

Phase Noise @ 20 GHz, P1dB

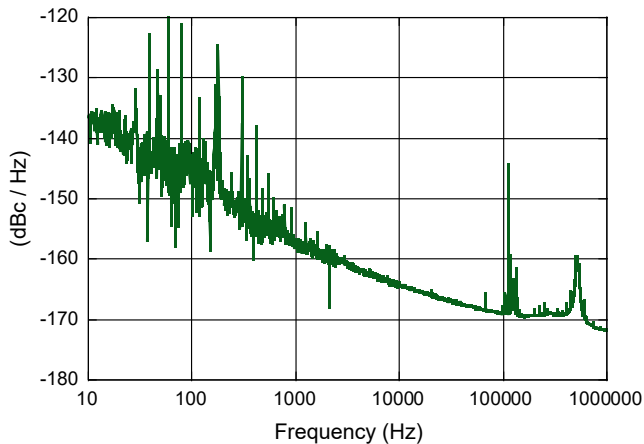

Phase Noise @ 20 GHz, P3dB

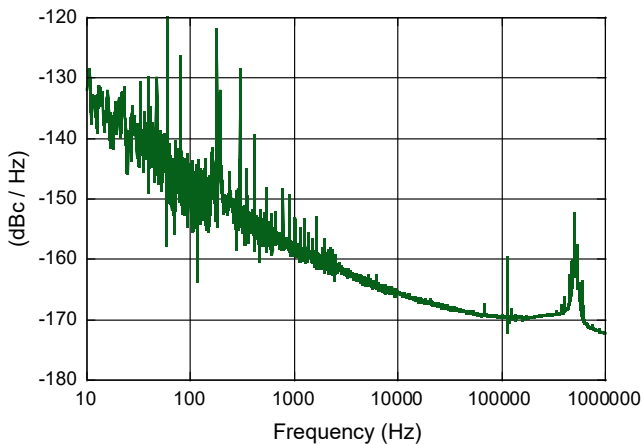

10 6. The aberration in the phase noise data at approximately 500 MHz is due to the test equipment used and not the amplifier itself.

MACOM Technology Solutions Inc. (MACOM) and its affiliates reserve the right to make changes to the product(s) or information contained herein without notice. Visit www.macom.com for additional data sheets and product information.

For further information and support please visit: <https://www.macom.com/support>

DC-0030533

Low Phase Noise Amplifier 2 - 30 GHz



MAAL-011158

Rev. V1

Typical Performance Curves: $V_{CC} = 6\text{ V}$, $I_{CC} = 135\text{ mA}$, $+25^\circ\text{C}$

Bias Current vs Input Power

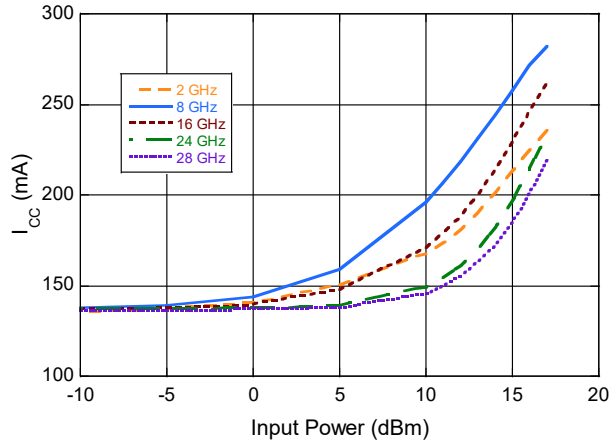

Test Board Line Loss, 1 port loss

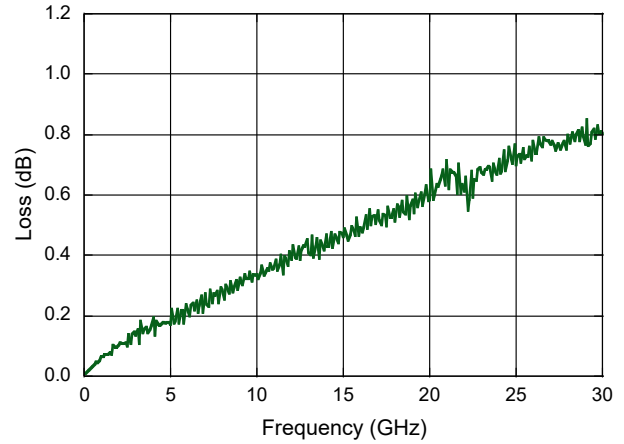

Low Phase Noise Amplifier

2 - 30 GHz



MAAL-011158

Rev. V1

Lead-Free 5 mm 32-Lead AQFN Package[†]

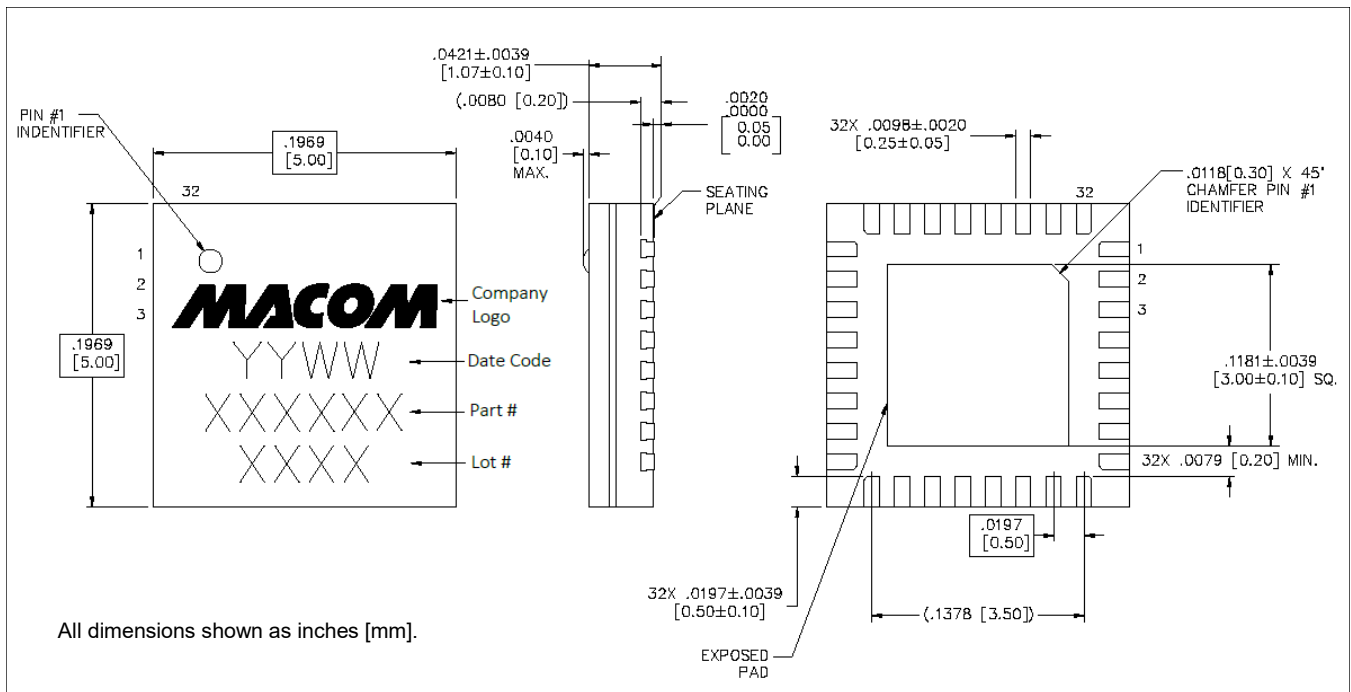

[†] Reference Application Note S2083 for lead-free solder reflow recommendations.
 Meets JEDEC moisture sensitivity level 3 requirements.
 Plating is NiPdAu.

MACOM Technology Solutions Inc. ("MACOM"). All rights reserved.

These materials are provided in connection with MACOM's products as a service to its customers and may be used for informational purposes only. Except as provided in its Terms and Conditions of Sale or any separate agreement, MACOM assumes no liability or responsibility whatsoever, including for (i) errors or omissions in these materials; (ii) failure to update these materials; or (iii) conflicts or incompatibilities arising from future changes to specifications and product descriptions, which MACOM may make at any time, without notice. These materials grant no license, express or implied, to any intellectual property rights.

THESE MATERIALS ARE PROVIDED "AS IS" WITH NO WARRANTY OR LIABILITY, EXPRESS OR IMPLIED, RELATING TO SALE AND/OR USE OF MACOM PRODUCTS INCLUDING FITNESS FOR A PARTICULAR PURPOSE, MERCHANTABILITY, INFRINGEMENT OF INTELLECTUAL PROPERTY RIGHT, ACCURACY OR COMPLETENESS, OR SPECIAL, INDIRECT, INCIDENTAL, OR CONSEQUENTIAL DAMAGES WHICH MAY RESULT FROM USE OF THESE MATERIALS.

MACOM products are not intended for use in medical, lifesaving or life sustaining applications. MACOM customers using or selling MACOM products for use in such applications do so at their own risk and agree to fully indemnify MACOM for any damages resulting from such improper use or sale.