

Low Phase Noise Amplifier 2 - 28 GHz



MAAL-011158-DIE

Rev. V2

Features

- Phase Noise: -172 dBc/Hz @ 10 kHz
- Gain: 12 dB
- P_{SAT} : +24 dBm
- Bias Voltage: $V_{CC} = +6 V$
- Bias Current: $I_{CQ} = 135 mA$
- 50 Ω Matched Input and Output
- Positive Voltage Only
- Die Size: 3000 x 1300 x 100 μm
- RoHS* Compliant

Applications

- Radar
- Electronic Countermeasures
- Test and Measurement
- Microwave Communication Systems

Description

The MAAL-011158-DIE is an easy to use low phase noise amplifier chip. It operates from 2 - 28 GHz and provides -172 dBc/Hz phase noise, 12 dB gain and +24 dBm P_{SAT} . The input and output are fully matched to 50 Ω with typical return loss >14 dB.

This product is fabricated using a GaAs HBT process which features full passivation for enhanced reliability.

Functional Schematic

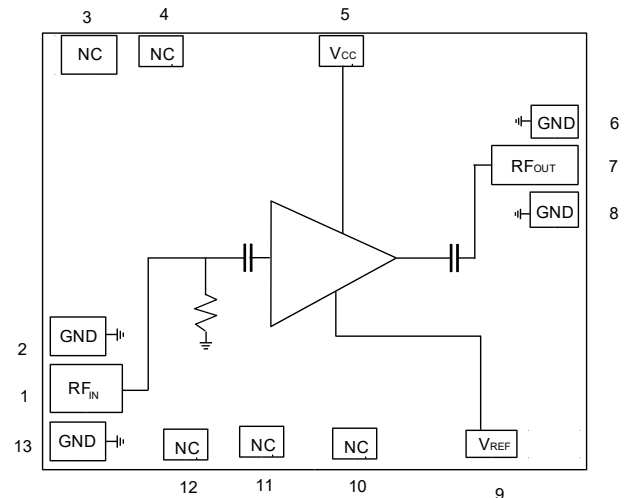

Pad Configuration¹

Pad #	Pad Name	Description
2,6,8,13	GND	DC + RF Ground to Backside Via
1	RF _{IN}	RF Input
3,4,10,11,12	NC	Not Connected
5	V _{CC}	Supply Voltage
7	RF _{OUT}	RF Output
9	V _{REF}	Reference Voltage

1. Backside of die must be connected to RF, DC and thermal ground.

Ordering Information

Part Number	Package
MAAL-011158-DIE	Gel Pack

* Restrictions on Hazardous Substances, compliant to current RoHS EU directive.

Low Phase Noise Amplifier

2 - 28 GHz



MAAL-011158-DIE

Rev. V2

Electrical Specifications: Freq. = 2 - 28 GHz, T_A = +25°C, V_{CC} = 6 V, Z₀ = 50 Ω
(Based on probed die production data)

Parameter	Test Conditions	Units	Min.	Typ.	Max.
Gain	P _{IN} = -10 dBm, 6 GHz P _{IN} = -10 dBm, 18 GHz P _{IN} = -10 dBm, 28 GHz	dB	10 10 8	12 12 10	—
Gain Flatness	—	dB	—	±1	—
Gain Variation over Temperature	—	dB/°C	—	0.011	—
Output Power	P _{IN} = +13 dBm, 6 GHz P _{IN} = +10 dBm, 18 GHz P _{IN} = +8.5 dBm, 28 GHz	dBm	22 19 15	24 21 17.5	—
Noise Figure	—	dB	—	4.0	—
Input Return Loss	—	dB	—	15	—
Output Return Loss	—	dB	—	14	—
P1dB	16 GHz	dBm	—	22	—
P _{SAT}	16 GHz	dBm	—	25	—
OIP3	16 GHz, -10 dBm P _{IN} per tone	dBm	—	32.5	—
Phase Noise	10 GHz, Psat 100 Hz 1 kHz 10 kHz 1 MHz	dBc/Hz	—	-148 -164 -172 -178	—
I _{cq}	—	mA	—	135	—

Absolute Maximum Ratings^{2,3}

Parameter	Absolute Maximum
Input Power	19 dBm
V _{CC}	7.5 V
I _{CC}	350 mA
Junction Temperature ^{4,5}	+130°C
Operating Temperature	-40°C to +85°C
Storage Temperature	-65°C to +125°C

- Exceeding any one or combination of these limits may cause permanent damage to this device.
- MACOM does not recommend sustained operation near these survivability limits.
- Operating at nominal conditions with T_J ≤ +130°C will ensure MTTF > 1 x 10⁶ hours.
- Junction Temperature (T_J) = T_C + Θ_{Jc} * (V * I)
Typical thermal resistance (Θ_{Jc}) = 16.4 °C/W.
a) For T_C = +25°C,
T_J = 59.4°C @ 7.5 V, 280 mA
b) For T_C = +85°C,
T_J = 119.4°C @ 7.5 V, 280 mA

Maximum Operating Conditions

Parameter	Maximum
Input Power	17 dBm
V _{CC}	7 V
I _{CC}	280 mA
Junction Temperature	+130°C
Operating Temperature	-40°C to +85°C
Storage Temperature	-65°C to +125°C

Handling Procedures

Please observe the following precautions to avoid damage:

Static Sensitivity

These electronic devices are sensitive to electrostatic discharge (ESD) and can be damaged by static electricity. Proper ESD control techniques should be used when handling these HBM Class 1A, 250 V devices.

PCB Layout

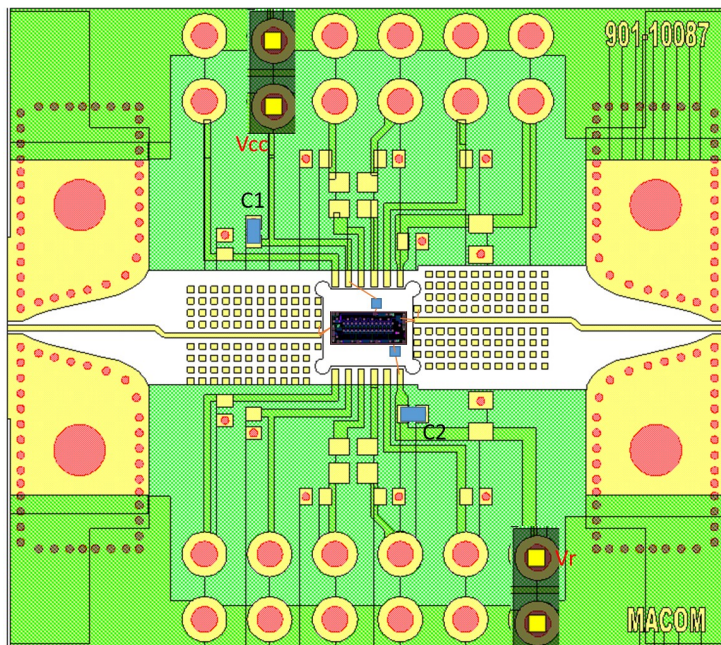

shortest possible wire length

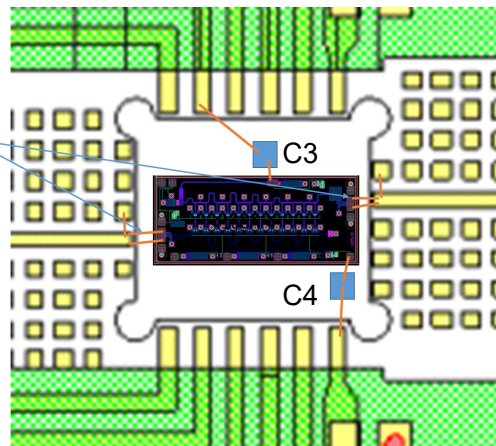

Application Schematic

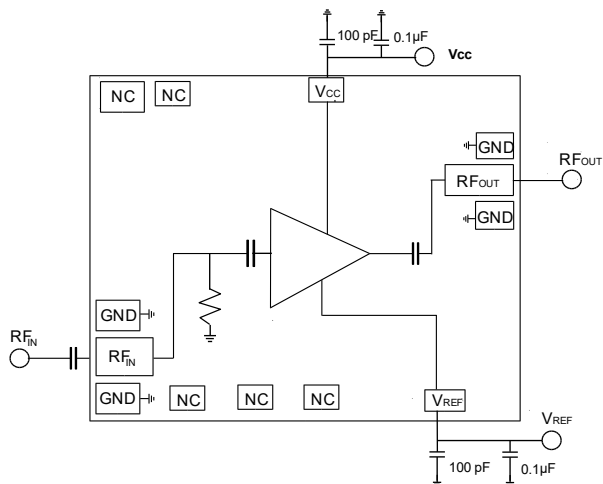

Operation

- To turn-on:
1. Apply +6 V to V_{CC}
 2. Starting at 0 V, adjust V_{REF} for target I_{CC} (+2 V typical)

- To turn-off:
1. Set V_{REF} to 0 V
 2. Set V_{CC} to 0 V

Evaluation PCB Specifications

Top Layer: 1/2 oz Copper Cladding, 0.017 mm thickness
 Dielectric Layer: Rogers RO4350B 0.101 mm thickness
 Bottom Layer: 1/2 oz Copper Cladding, 0.017 mm thickness
 Finished overall thickness: 0.135 mm

Parts List

Part	Value	Case Style	MFG	MFG Part #
C3, C4	100 pF	Single Layer	MACOM	MC2S100025-025
C1, C2	0.1 μF	0402	KYOCERA	04023C103KAT2A

Low Phase Noise Amplifier

2 - 28 GHz



MAAL-011158-DIE

Rev. V2

Typical Performance Curves: $V_{CC} = 6\text{ V}$, $I_{CC} = 135\text{ mA}$

Gain

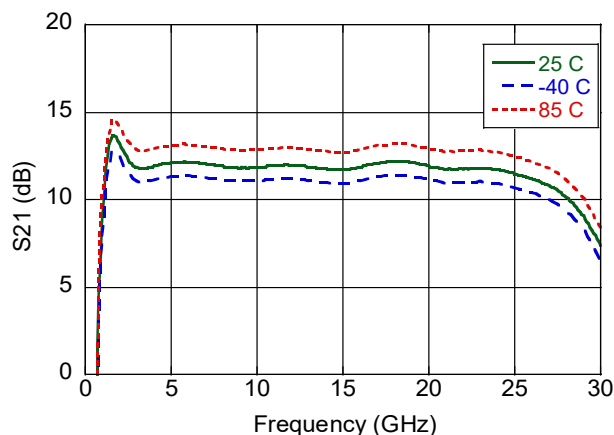

Input Return Loss

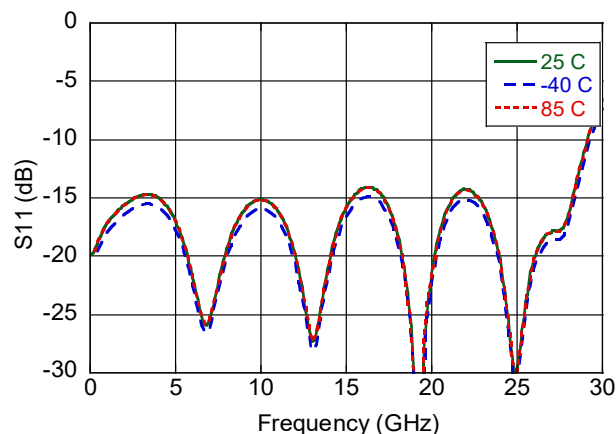

Output Return Loss

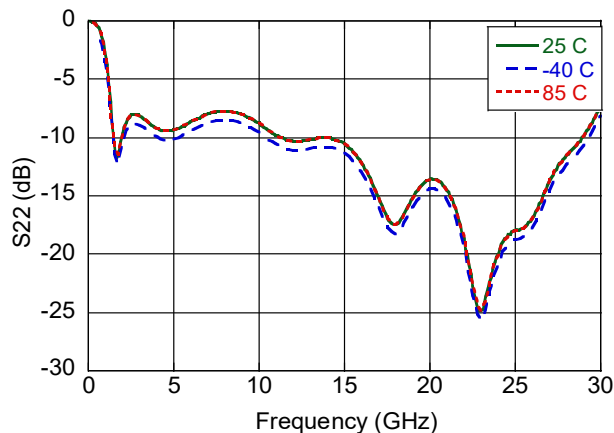

Reverse Isolation

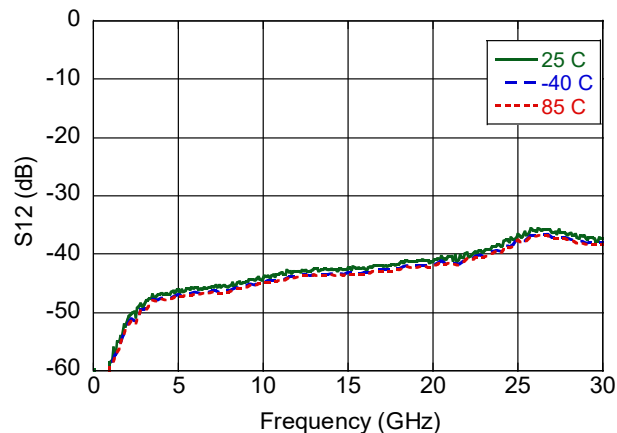

P1dB

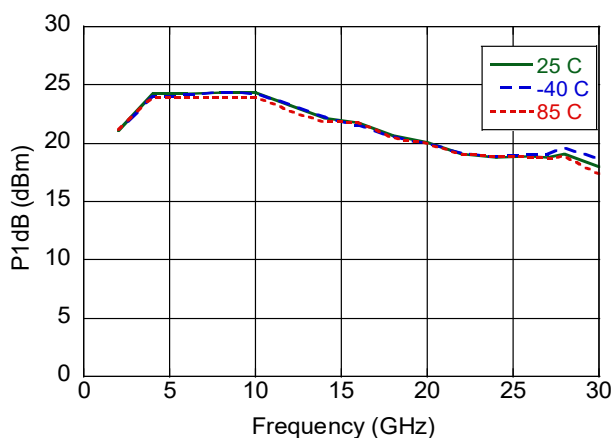

P_{SAT}

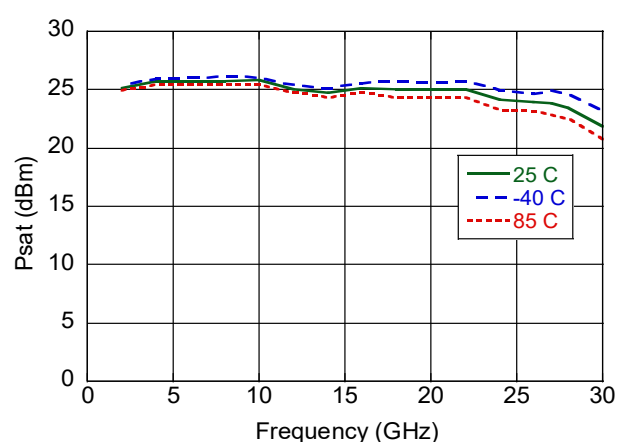

Typical Performance Curves: $I_{CC} = 135 \text{ mA}$, $+25^\circ\text{C}$

Gain

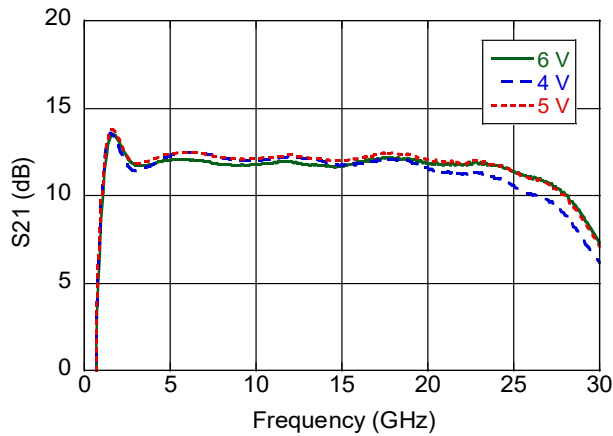

Input Return Loss

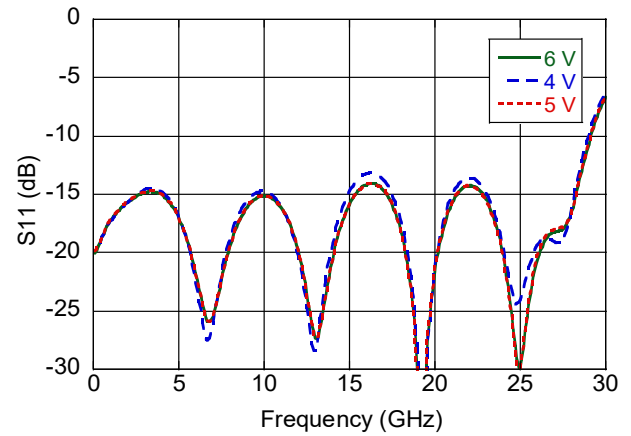

Output Return Loss

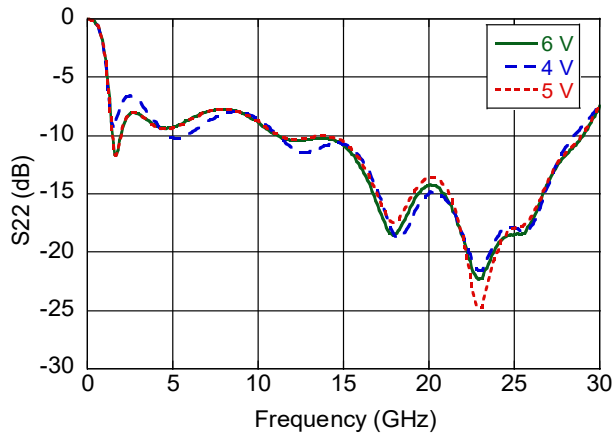

Reverse Isolation

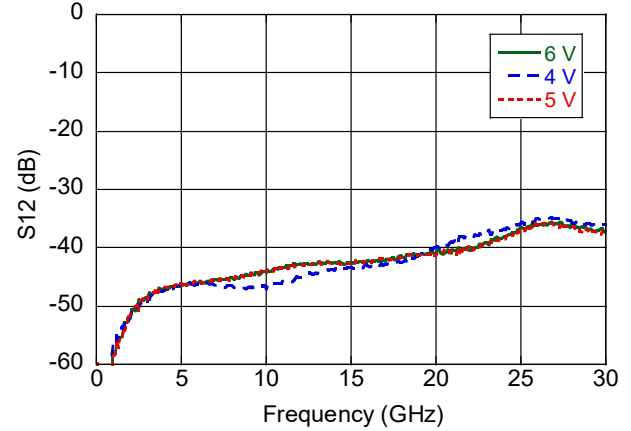

P1dB

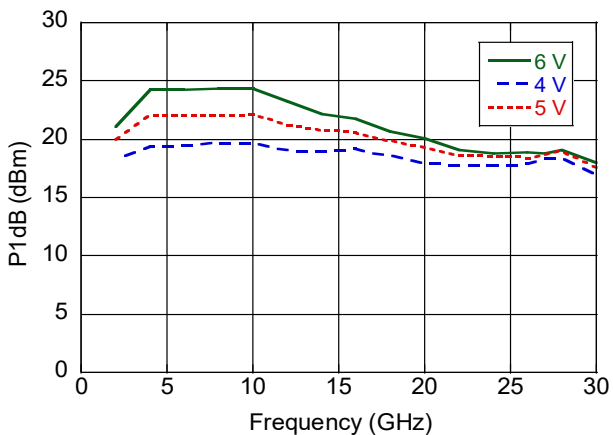

P_{SAT}

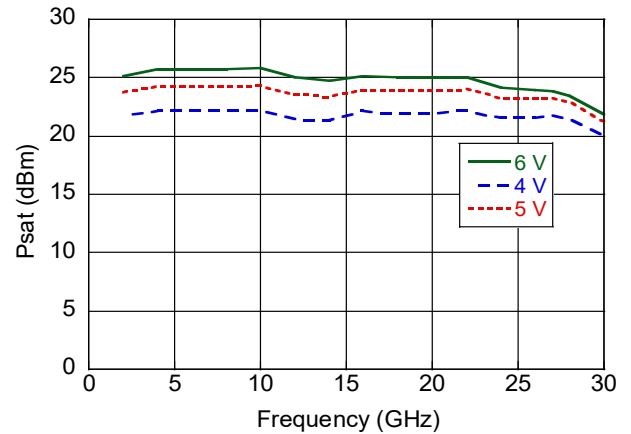

Low Phase Noise Amplifier

2 - 28 GHz



MAAL-011158-DIE

Rev. V2

Typical Performance Curves: $V_{CC} = 6\text{ V}$, $+25^\circ\text{C}$

Gain

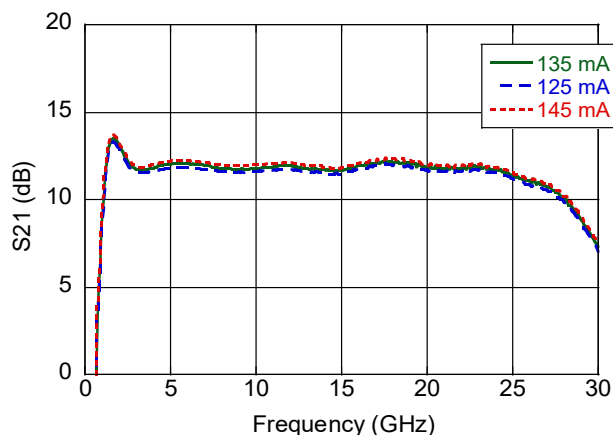

Input Return Loss

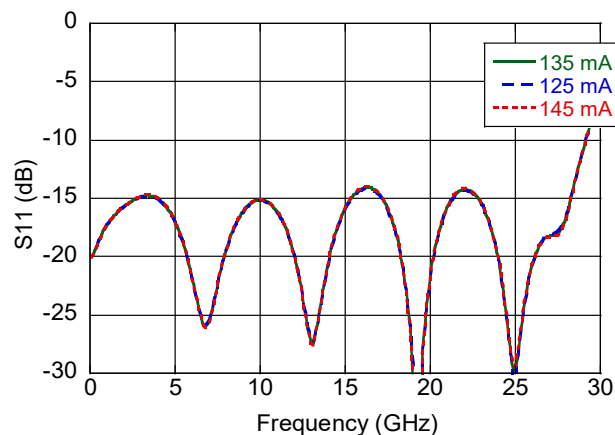

Output Return Loss

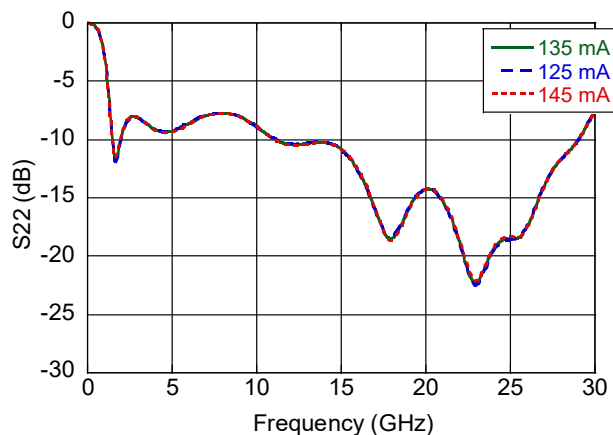

Reverse Isolation

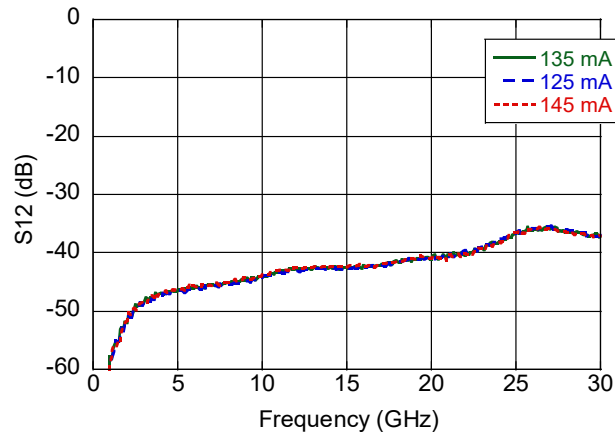

P1dB

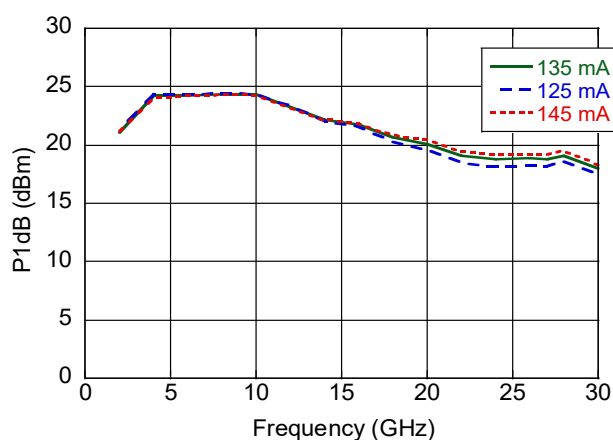

P_{SAT}

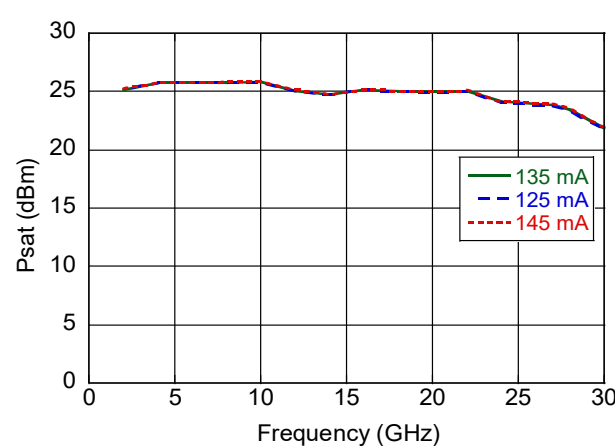

Low Phase Noise Amplifier

2 - 28 GHz



MAAL-011158-DIE

Rev. V2

Typical Performance Curves: $V_{CC} = 6\text{ V}$, $I_{CC} = 135\text{ mA}$, $+25^\circ\text{C}$

Output IP3

(10 MHz Tone Spacing, $P_{IN} = -5\text{ dBm}$ per tone)

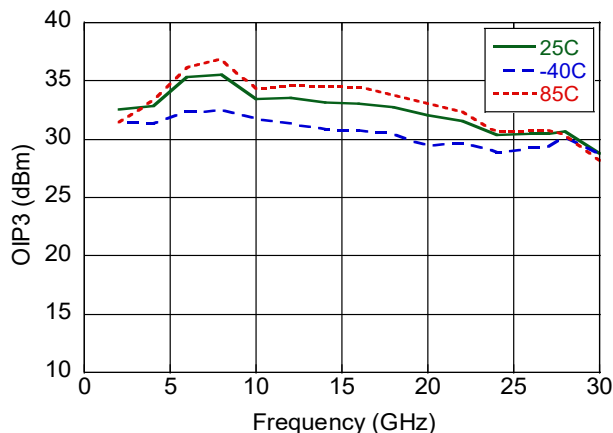

Noise Figure

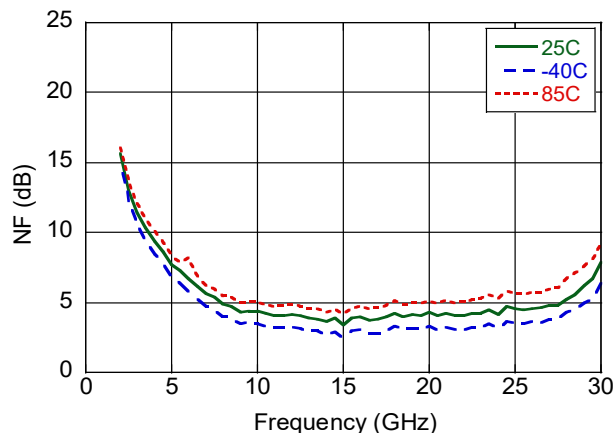

Output IP3

(10 MHz Tone Spacing, $P_{IN} = -5\text{ dBm}$ per tone)

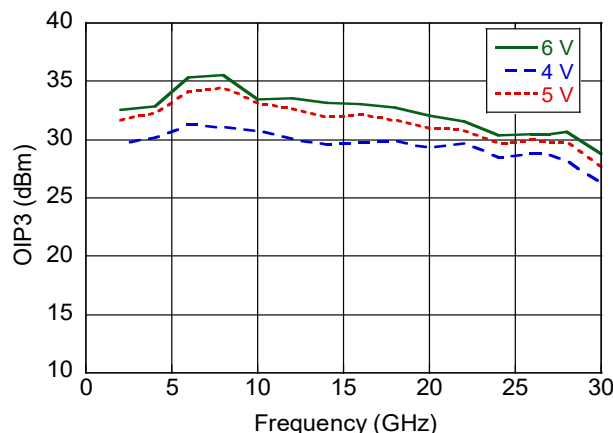

Noise Figure

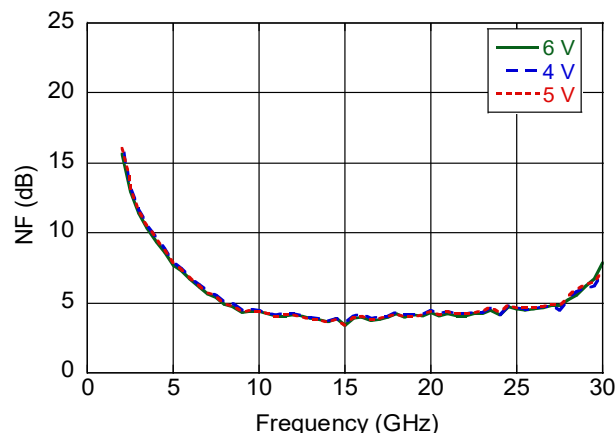

Output IP3

(10 MHz Tone Spacing, $P_{IN} = -5\text{ dBm}$ per tone)

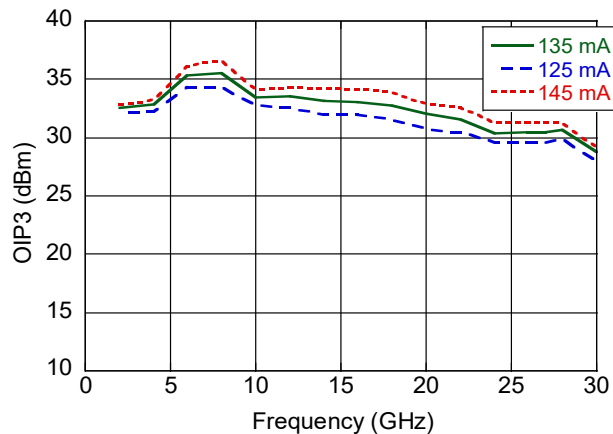

Noise Figure

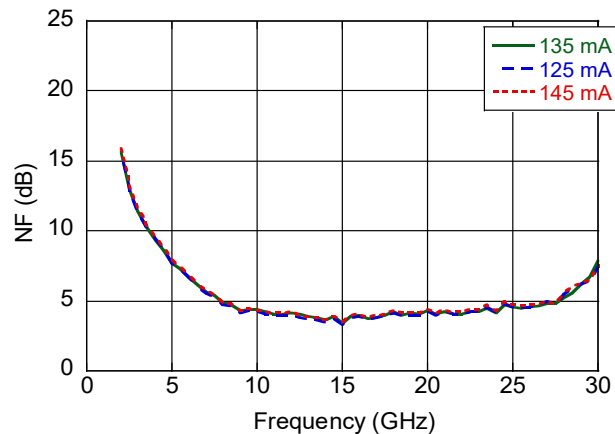

Low Phase Noise Amplifier

2 - 28 GHz



MAAL-011158-DIE

Rev. V2

Typical Performance Curves⁶: $I_{CC} = 135 \text{ mA}$, $+25^\circ\text{C}$

Phase Noise @ 4 GHz, P1dB

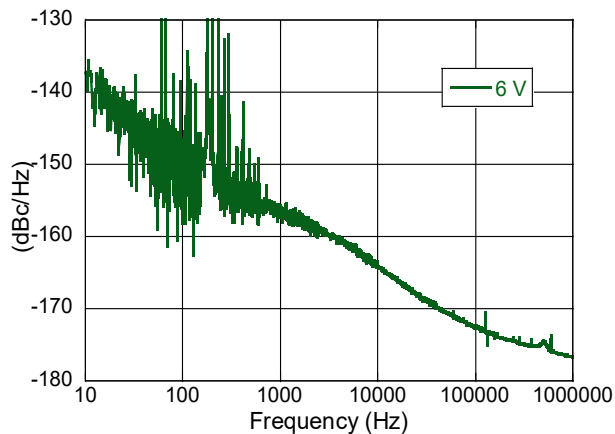

Phase Noise @ 4 GHz, P4dB

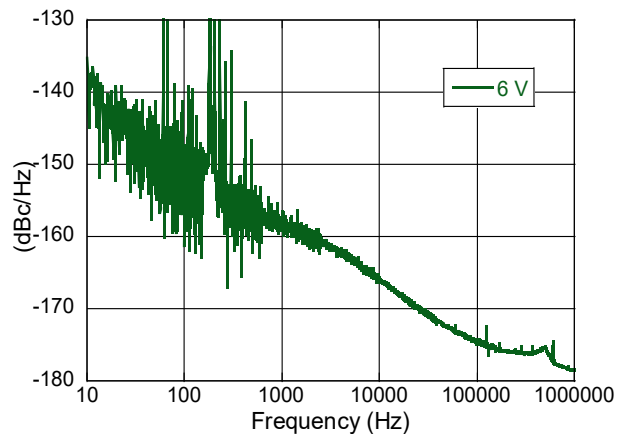

Phase Noise @ 10 GHz, P1dB

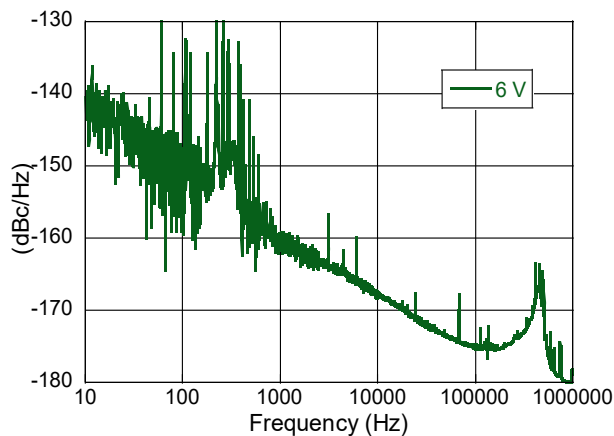

Phase Noise @ 10 GHz, P3dB

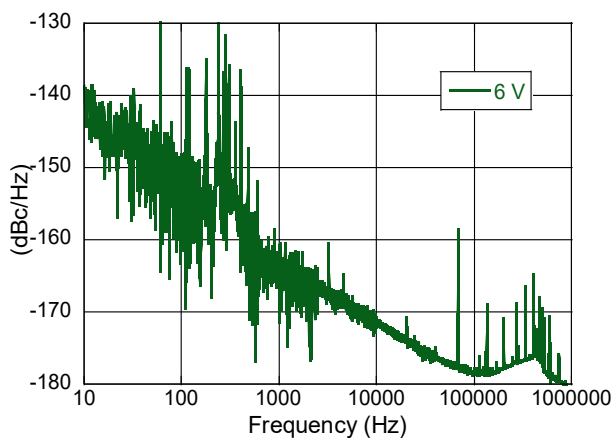

Phase Noise @ 20 GHz, P1dB

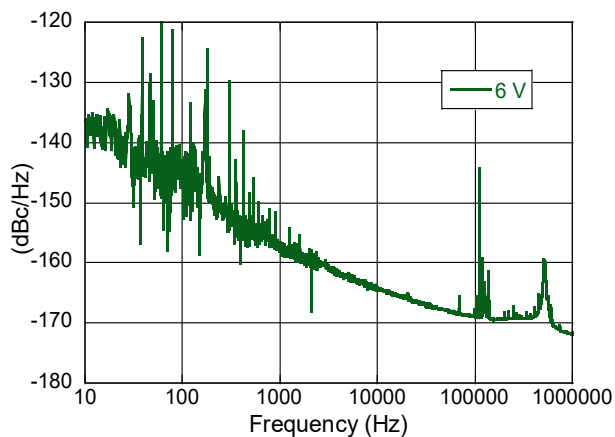

Phase Noise @ 20 GHz, P3dB

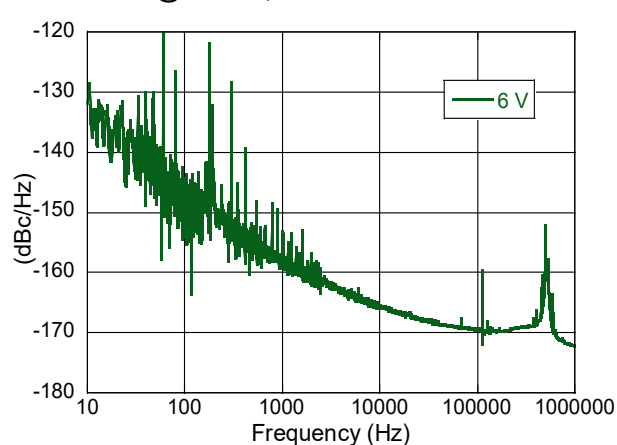

8 6. The aberration in the phase noise data at approximately 500 MHz is due to the test equipment used and not the amplifier itself.

MACOM Technology Solutions Inc. (MACOM) and its affiliates reserve the right to make changes to the product(s) or information contained herein without notice. Visit www.macom.com for additional data sheets and product information.

Low Phase Noise Amplifier 2 - 28 GHz



MAAL-011158-DIE

Rev. V2

Typical Performance Curves: $V_{CC} = 6\text{ V}$, $I_{CC} = 135\text{ mA}$, $+25^\circ\text{C}$

Bias Current vs Input Power

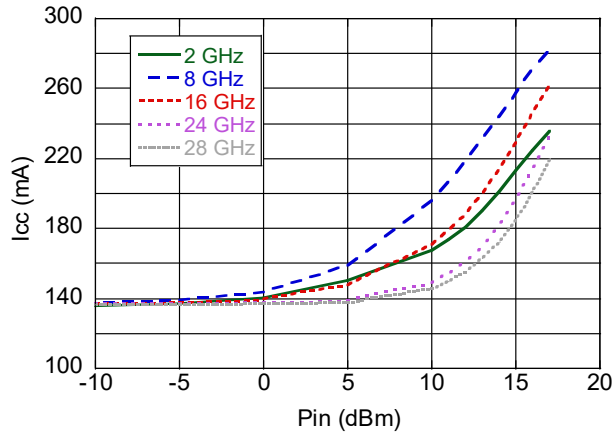

Test Board Loss

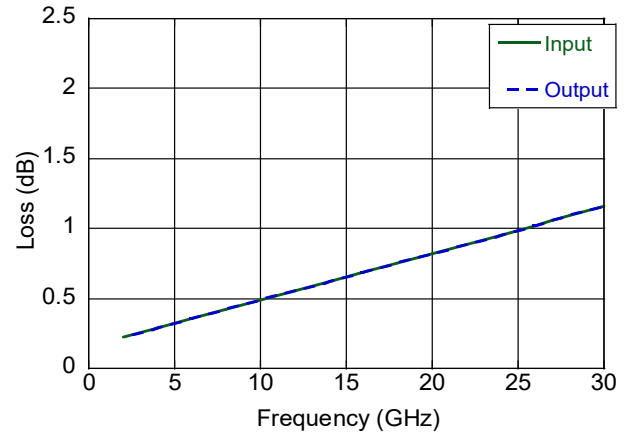

Low Phase Noise Amplifier 2 - 28 GHz



MAAL-011158-DIE

Rev. V2

MMIC Die Outline

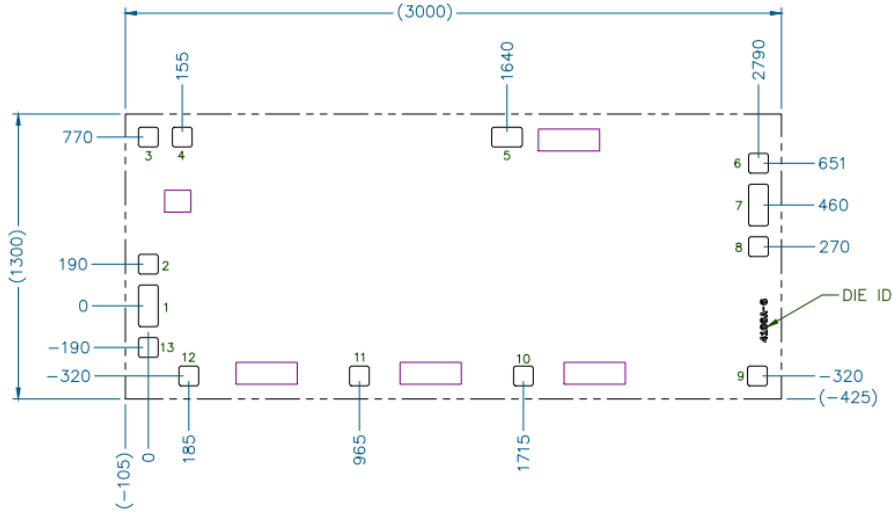

BONDPAD DETAIL		
PAD	SIZE(x)	SIZE(y)
1,7	100	200
2,3,4,6,8,9,10,11,12,13	100	100
5	150	100

NOTES:

- UNLESS OTHERWISE SPECIFIED, ALL DIMENSIONS SHOWN ARE μm WITH A TOLERANCE OF $\pm 5\mu\text{m}$.
- DIE THICKNESS IS $100 \pm 10\mu\text{m}$
- BOND/PAD BACKSIDE METALLIZATION: GOLD
- DIE SIZE REFLECTS FINAL DIMENSIONS.

MACOM Technology Solutions Inc. ("MACOM"). All rights reserved.

These materials are provided in connection with MACOM's products as a service to its customers and may be used for informational purposes only. Except as provided in its Terms and Conditions of Sale or any separate agreement, MACOM assumes no liability or responsibility whatsoever, including for (i) errors or omissions in these materials; (ii) failure to update these materials; or (iii) conflicts or incompatibilities arising from future changes to specifications and product descriptions, which MACOM may make at any time, without notice. These materials grant no license, express or implied, to any intellectual property rights.

THESE MATERIALS ARE PROVIDED "AS IS" WITH NO WARRANTY OR LIABILITY, EXPRESS OR IMPLIED, RELATING TO SALE AND/OR USE OF MACOM PRODUCTS INCLUDING FITNESS FOR A PARTICULAR PURPOSE, MERCHANTABILITY, INFRINGEMENT OF INTELLECTUAL PROPERTY RIGHT, ACCURACY OR COMPLETENESS, OR SPECIAL, INDIRECT, INCIDENTAL, OR CONSEQUENTIAL DAMAGES WHICH MAY RESULT FROM USE OF THESE MATERIALS.

MACOM products are not intended for use in medical, lifesaving or life sustaining applications. MACOM customers using or selling MACOM products for use in such applications do so at their own risk and agree to fully indemnify MACOM for any damages resulting from such improper use or sale.