

## Features

- Extremely Low Parasitic Capacitance & Inductance
- Surface Mountable in Microwave Circuits, No Wirebonds Required
- Rugged HMIC Construction with Polyimide Scratch Protection
- Reliable, Multilayer Metalization with a Diffusion Barrier, 100% Stabilization Bake (300°C, 16 hours)

## Description

The MA4E2508 SURMOUNT™ Anti-Parallel Diode Series are Silicon Low, Medium, & High Barrier Schottky Devices fabricated with the patented Heterolithic Microwave Integrated Circuit (HMIC) process. HMIC circuits consist of Silicon pedestals which form diodes or via conductors embedded in a glass dielectric, which acts as the low dispersion, low loss, microstrip transmission medium. The combination of silicon and glass allows HMIC devices to have excellent loss and power dissipation characteristics in a low profile, reliable device.

The Surmount Schottky devices are excellent choices for circuits requiring the small parasitics of a beam lead device coupled with the superior mechanical performance of a chip. The SurMount structure employs very low resistance silicon vias to connect the Schottky contacts to the metalized mounting pads on the bottom surface of the chip. These devices are reliable, repeatable, and a lower cost performance solution to conventional devices. They have lower susceptibility to electrostatic discharge than conventional beam lead Schottky diodes.

The multi-layer metalization employed in the fabrication of the Surmount Schottky junctions includes a platinum diffusion barrier, which permits all devices to be subjected to a 16-hour non-operating stabilization bake at 300°C.

The “0502” outline allows for Surface Mount placement and multi- functional polarity orientations.

## Case Style 1112

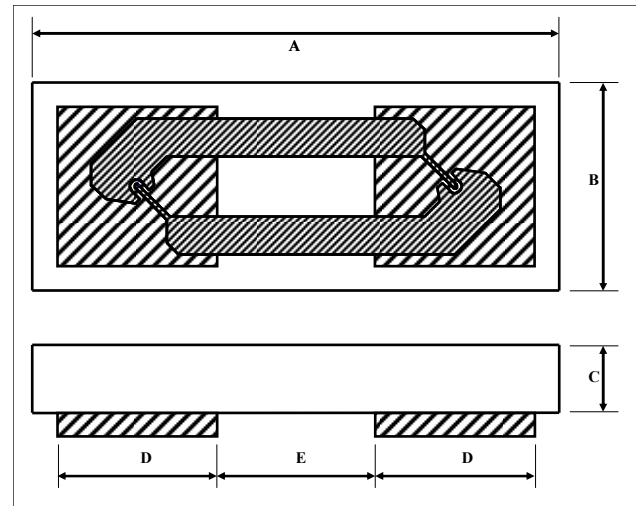

## Case Style 1112

DIM	INCHES		MILLIMETERS	
	MIN.	MAX.	MIN.	MAX.
A	0.0445	0.0465	1.130	1.180
B	0.0169	0.0189	0.430	0.480
C	0.0040	0.0080	0.102	0.203
D Sq.	0.0128	0.0148	0.325	0.375
E	0.0128	0.0148	0.325	0.375

## Equivalent Circuit

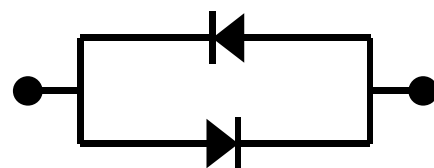

Low Barrier = MA4E2508L, Medium Barrier = MA4E2508M, High Barrier = MA4E2508H

## Electrical Specifications: $T_A = +25^\circ\text{C}^{1,2}$

Model Number	Barrier	Recommended Freq. Range (GHz)	$V_F @ 1 \text{ mA}$ (mV)	$CT @ 0 \text{ V}$ (pF)	$R_T$ Slope Resistance ( $V_{F1} - V_{F2}$ ) / (10.5 mA - 9.5 mA) ( $\Omega$ )
MA4E2508L	Low	DC - 18	330 max. 300 typ.	0.24 max. 0.18 typ.	16 typ. 20 max.
MA4E2508M	Medium	DC - 18	470 max. 420 typ.	0.24 max. 0.18 typ.	12 typ. 18 max.
MA4E2508H	High	DC - 18	700 max. 650 typ.	0.24 max. 0.18 typ.	11 typ. 15 max.

- $R_T$  is the dynamic slope resistance where  $R_T = R_S + R_J$ , where  $R_J = 26 / I_{DC}$  ( $I_{DC}$  is in mA) and  $R_S$  is the ohmic resistance.
- Maximum forward voltage difference  $DV_f @ 1 \text{ mA}$ : 10 mV

## Spice Parameters (Per Diode)<sup>3</sup>

Barrier	$I_S$ (nA)	$R_S$ ( $\Omega$ )	N	$C_{J0}$ (pF)	M	$I_K$ (mA)	$C_J$ par (pF)	$V_J$ (V)	FC	BV (V)	IBV (mA)
Low	26	12.8	1.20	1.0 E-2	0.5	14	9.0 E-2	8.0 E-2	0.5	5.0	1.0 E-2
Medium	5.0 E-1	9.6	1.20	1.0 E-2	0.5	10	9.0 E-2	8.0 E-2	0.5	5.0	1.0 E-2
High	5.7 E-2	6.5	1.20	1.0 E-2	0.5	4	9.0 E-2	8.0 E-2	0.5	5.0	1.0 E-2

- Spice parameters (Per Diode) are based on the MA4E2502 Series datasheet.

## Absolute Maximum Ratings @ $+25^\circ\text{C}$

Parameter	Absolute Maximum
Forward Current	20 mA
Reverse Voltage	5 V
RF CW Incident Power	20 dBm
RF & DC Dissipated Power	50 mW
Junction Temperature	$+175^\circ\text{C}$
Operating Temperature	$-40^\circ\text{C}$ to $+125^\circ\text{C}$
Storage Temperature	$-40^\circ\text{C}$ to $+150^\circ\text{C}$

- Exceeding any one or combination of these limits may cause permanent damage to this device.
- MACOM does not recommend sustained operation near these survivability limits.

## Handling Procedures

Please observe the following precautions to avoid damage:

## Static Sensitivity

These electronic devices are sensitive to electrostatic discharge (ESD) and can be damaged by static electricity. Proper ESD control techniques should be used when handling these Class 0 devices.

## Circuit Mounting Dimensions (Inches)

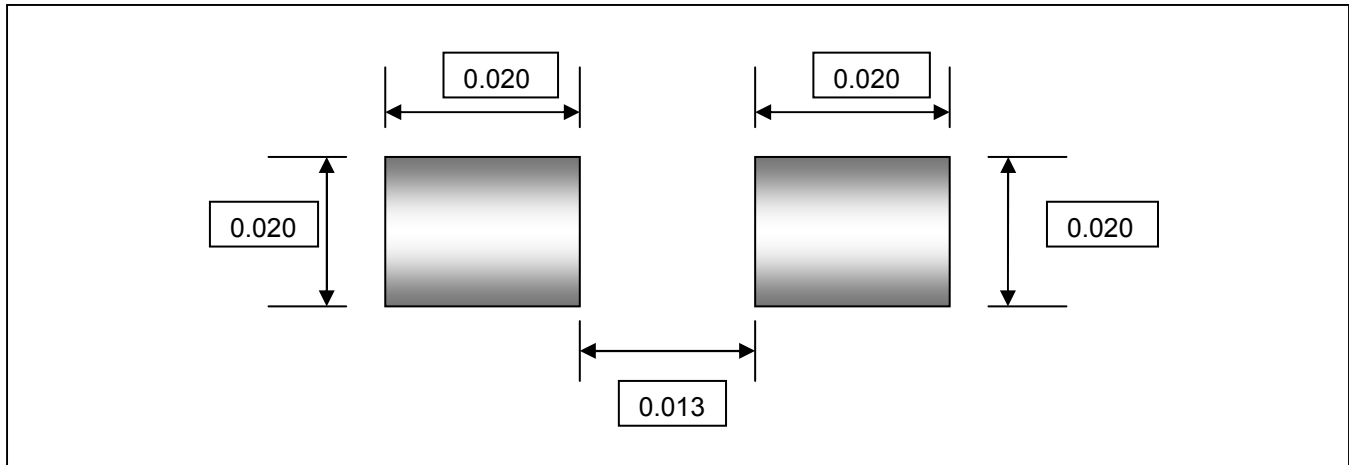

## Applications

The MA4E2508 family of surmount Schottky diodes are recommended for use in microwave circuits through Ku band frequencies for lower power applications such as mixers, sub-harmonic mixers, detectors and limiters. The HMIC construction facilitates the direct replacement of more fragile beam lead diodes with the corresponding surmount diode, which can be connected to a hard or soft substrate circuit with solder.

## Handling

All semiconductor chips should be handled with care to avoid damage or contamination from perspiration and skin oils. The use of plastic tipped tweezers or vacuum pickups is strongly recommended for individual components. The top surface of the die has a protective polyimide coating to minimize the damage.

The rugged construction of these surmount devices allows the use of standard handling and die attach techniques. It is important to note that industry standard electrostatic discharge (ESD) control is required at all times, due to the sensitive nature of Schottky junctions. Bulk handling should insure that abrasion and mechanical shock are minimized.

## Die Bonding

Die attach for these devices is made simple through the use of surface mount die attach technology. Mounting pads are conveniently located on the bottom surface of these devices, and are opposite the active junction. The devices are well suited for higher temperature solder attachment onto hard substrates.

For hard substrates, we recommend utilizing a vacuum tip and force of 60 to 100 grams applied uniformly to the top surface of the device, using a hot gas bonder with equal heat applied across the bottom mounting pads of the device. When soldering to soft substrates, it is recommended to use a lead-tin interface at the circuit board mounting pads. Position the die so that its mounting pads are aligned with the circuit board mounting pads. Reflow the solder paste by applying equal heat to the circuit at both die-mounting pads. The solder joint must not be made one at a time, creating un-equal heat flow and thermal stress. Solder reflow should not be performed by causing heat to flow through the top surface of the die. Since the HMIC glass is transparent, the edges of the mounting pads can be visually inspected through the die after die attach is completed.

## MA4E2508 Schematic Per Diode

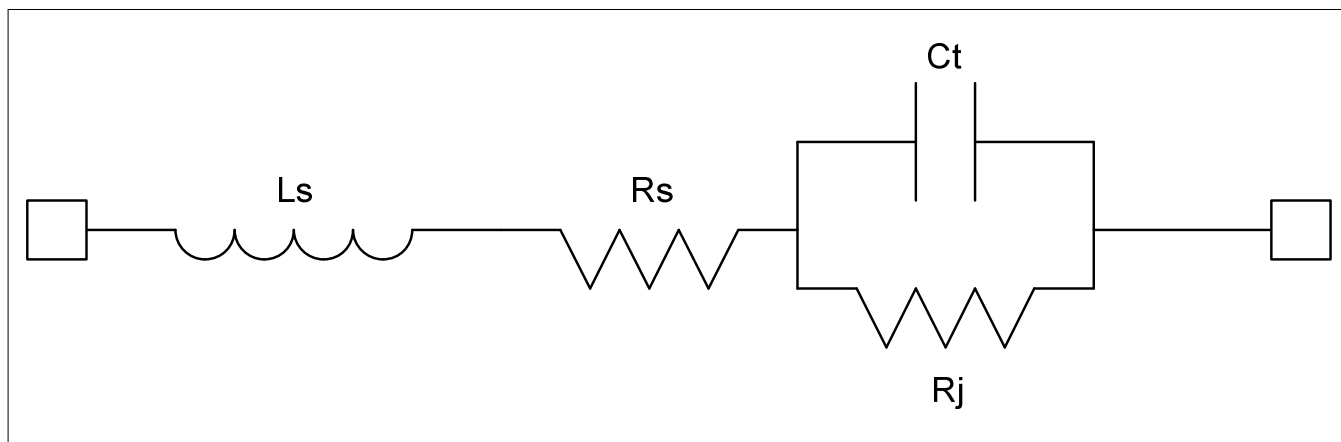

## Schematic Values per Diode

Model Number	$L_s$ (nH)	$R_s$ ( $\Omega$ )	$R_j$ ( $\Omega$ )	$C_T$ (pF)
MA4E2508L	0.8	12.8	26 / I <sub>dc</sub> (mA)	0.09
MA4E2508M	0.8	9.6	26 / I <sub>dc</sub> (mA)	0.09
MA4E2508H	0.8	6.5	26 / I <sub>dc</sub> (mA)	0.09

## Ordering Information

Part Number	Packaging
MA4E2508L-1112	100 die in carrier
MA4E2508M-1112	
MA4E2508H-1112	
MADS-002508-1112LP	3000 piece reel
MADS-002508-1112MP	
MADS-002508-1112HP	

M/A-COM Technology Solutions Inc. All rights reserved.

Information in this document is provided in connection with M/A-COM Technology Solutions Inc ("MACOM") products. These materials are provided by MACOM as a service to its customers and may be used for informational purposes only. Except as provided in MACOM's Terms and Conditions of Sale for such products or in any separate agreement related to this document, MACOM assumes no liability whatsoever. MACOM assumes no responsibility for errors or omissions in these materials. MACOM may make changes to specifications and product descriptions at any time, without notice. MACOM makes no commitment to update the information and shall have no responsibility whatsoever for conflicts or incompatibilities arising from future changes to its specifications and product descriptions. No license, express or implied, by estoppel or otherwise, to any intellectual property rights is granted by this document.

THESE MATERIALS ARE PROVIDED "AS IS" WITHOUT WARRANTY OF ANY KIND, EITHER EXPRESS OR IMPLIED, RELATING TO SALE AND/OR USE OF MACOM PRODUCTS INCLUDING LIABILITY OR WARRANTIES RELATING TO FITNESS FOR A PARTICULAR PURPOSE, CONSEQUENTIAL OR INCIDENTAL DAMAGES, MERCHANTABILITY, OR INFRINGEMENT OF ANY PATENT, COPYRIGHT OR OTHER INTELLECTUAL PROPERTY RIGHT. MACOM FURTHER DOES NOT WARRANT THE ACCURACY OR COMPLETENESS OF THE INFORMATION, TEXT, GRAPHICS OR OTHER ITEMS CONTAINED WITHIN THESE MATERIALS. MACOM SHALL NOT BE LIABLE FOR ANY SPECIAL, INDIRECT, INCIDENTAL, OR CONSEQUENTIAL DAMAGES, INCLUDING WITHOUT LIMITATION, LOST REVENUES OR LOST PROFITS, WHICH MAY RESULT FROM THE USE OF THESE MATERIALS.

MACOM products are not intended for use in medical, lifesaving or life sustaining applications. MACOM customers using or selling MACOM products for use in such applications do so at their own risk and agree to fully indemnify MACOM for any damages resulting from such improper use or sale.