

Ceramic Surface Mount Amplifier

Rev. V3

1. Introduction

M/A-COM's Ceramic Surface Mount amplifier platform offers superior intermodulation performance for IF amplifiers in a commercial LGA (Land Grid Array) package. This design approach integrates coupler feedback transformer technology into a low cost package with excellent thermal performance. The amplifiers in this family can be used individually or cascaded in pairs to achieve any gain between 10 and 30 dB in 5 dB steps.

Desired Gain (dB)	Stage 1 Amplifier	Stage 2 Amplifier	Prototype Amplifier
10	AM05-0006	N/A	AM05-0006-TB
15	AM05-0005	N/A	AM05-0005-TB
20	AM05-0006	AM05-0006	N/A
25	AM05-0005	AM05-0006	N/A
30	AM05-0005	AM05-0005	N/A

Table 1. Selection Guide for 10 to 30 dB Gain

2. Product Selection and Prototype Boards

For gains of 10 or 15 dB an individual AM05-0006 or AM05-0005 amplifier would be used. For gains of 20, 25, and 30 dB two amplifiers would be cascaded per Table 1. Note that for the 25 dB gain cascade, it is desirable to put AM05-0005 first, since noise figure is lower when the higher gain amplifier is the first element of the cascade.

Prototype boards are available for the AM05-0005 and AM05-0006 amplifiers. These boards are connectorized so the the customer can easier evaluate prototype quantities, without needing to develop prototype boards. DC voltage and return wires can be soldered or clipped to the DC connectors. The part numbers for the prototype boards are AM05-0005-TB and AM06-0006-TB. See Figure 1 for a prototype board with the AM05-0006 amplifier mounted to it.

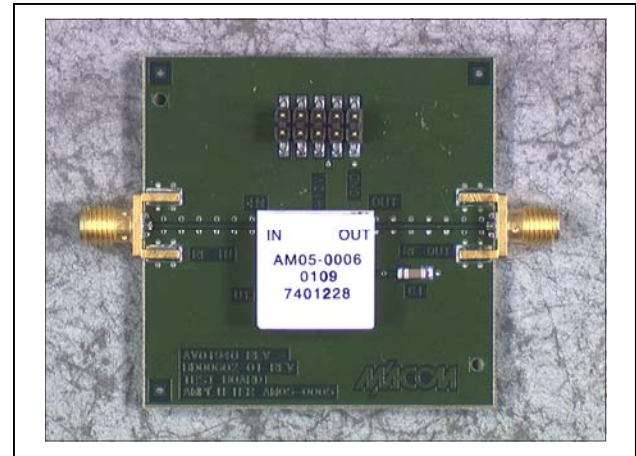

Figure 1. Prototype Board AM05-0006-TB

3. Package Design

The base of the package is ceramic due to the power dissipated in the transistor. Using a ceramic package is the best way to transfer heat out of the transistor, and still keep the design low cost for the commercial market. A land grid array package was used so that the amplifiers can easily be soldered to the end user's printed circuit board. There are two RF connections (RF IN and RF OUT) and a bias connection. All of the other connections are ground. The grounds are kept small to minimize mechanical stress on the solder joints as the temperature changes, due to the thermal expansion and contraction of the ceramic. Some of the grounds are actually used for thermal transfer, as opposed to just providing an RF ground. The leads are pretinned with solder to enhance soldering by the customer. See Figure 2 for a top and bottom view of the package.

Ceramic Surface Mount Amplifier

Rev. V3

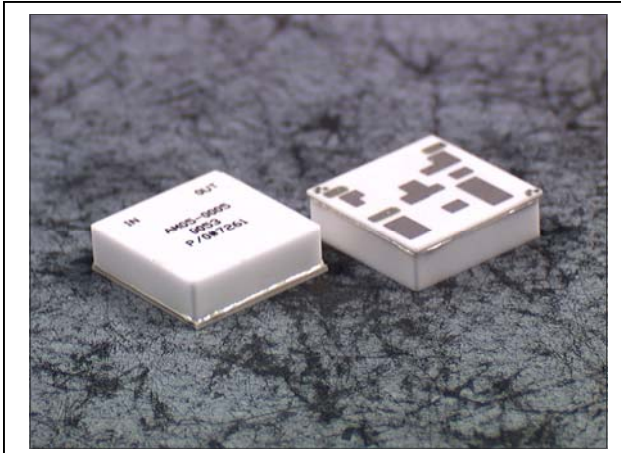

Figure 2. AM05-0005 Top and Bottom Views

4. Thermal Design Considerations

The power dissipated in the amplifiers is determined by the bias voltage and current. With a bias voltage of +12V and a typical current of 88 mA, the total power dissipation in an amplifier is 1.06 W. It is critical that the end user's PC board is designed so that 1.06 W can be removed from the vicinity of the amplifier. We recommend using 1 oz copper on the layer of the board where the ceramic SMT amplifiers are mounted. Note that the amplifiers should be soldered, not epoxied to the PC board.

5. PCB Design Guidelines

The outline drawing for the amplifier is provided in Figure 3. The actual pad sizes on the LGA bottom are defined here. When the amplifier is mounted to the PC board, use the "Recommended PC Board Mounting Pattern", which is provided in Figure 4. A dotted line indicates the physical size of the bottom of the package. It should be noted that the entire length of the RF traces on the ceramic should be soldered to the PC board. The RF traces on the PC board should then extend beyond the edge of the package as shown in Figure 4. This keeps the solder area larger, which increases the strength. This also allows for inspection of the solder joints.

The recommended solder for mounting surface mount packages is Sn63 (63% Sn, 37% Pb) because it is a eutectic compound with a melting point (183°C) high enough to exceed the standard operating limit of the devices, but low enough to avoid damaging internal circuitry during proper solder reflow operations.

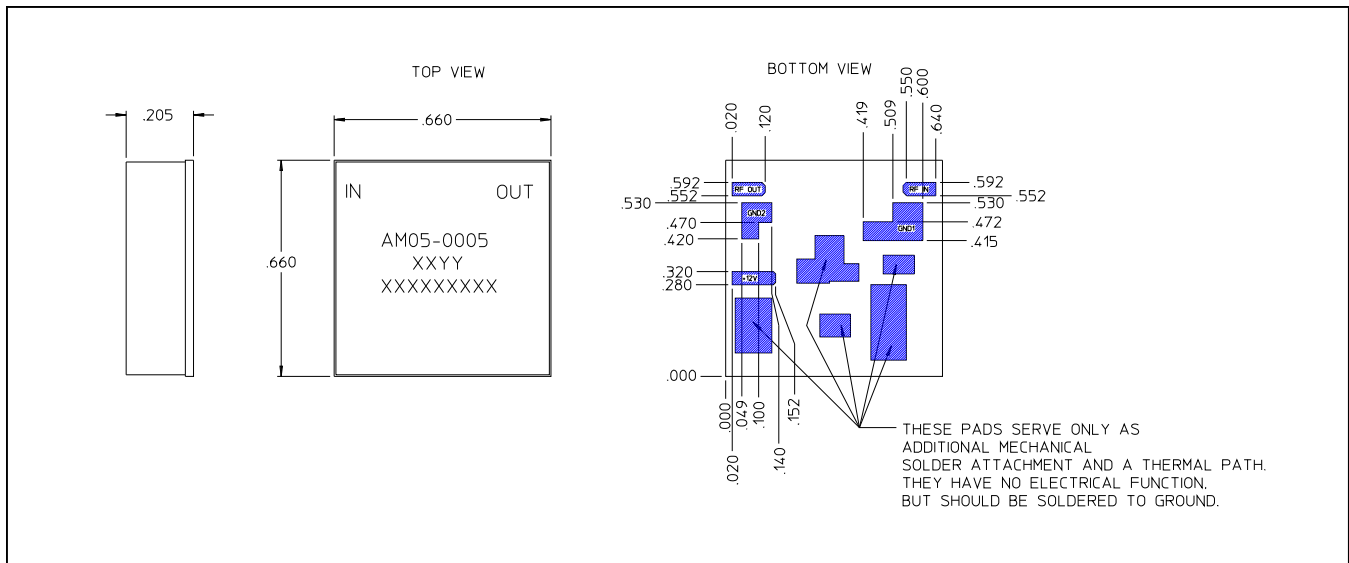

Figure 3. AM05-0005 Outline Drawing

Ceramic Surface Mount Amplifier

Rev. V3

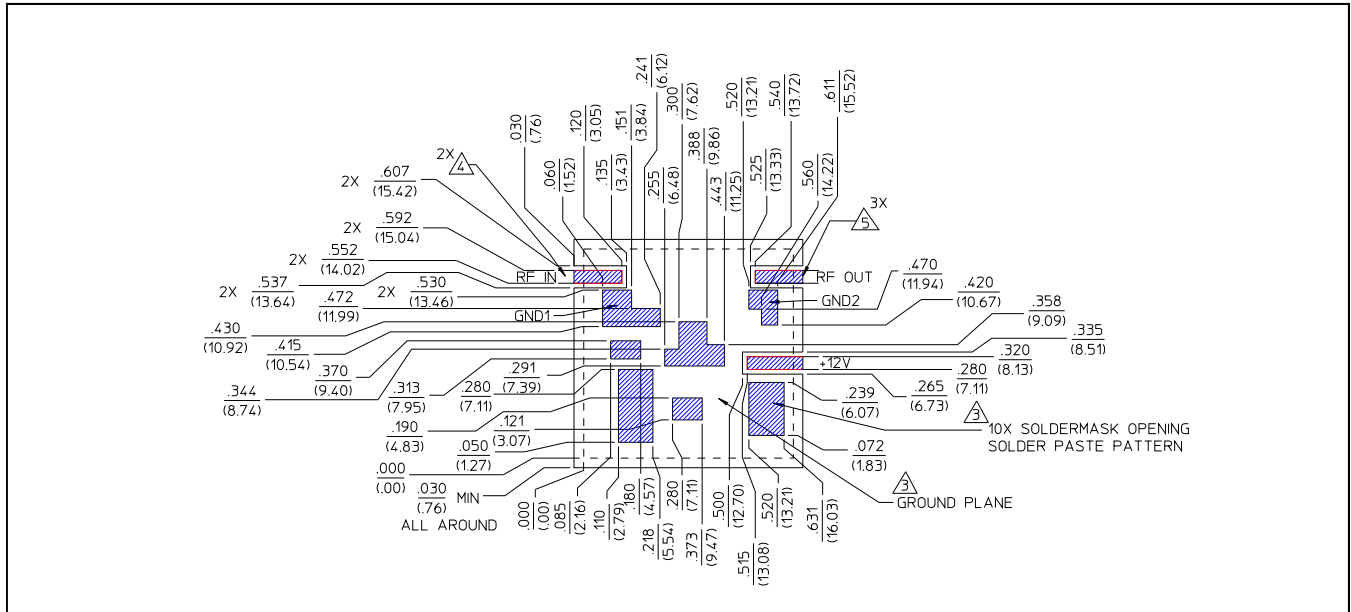

Figure 4. Recommended PC Board Mounting Pattern for AM05-0005/6 Amplifiers